

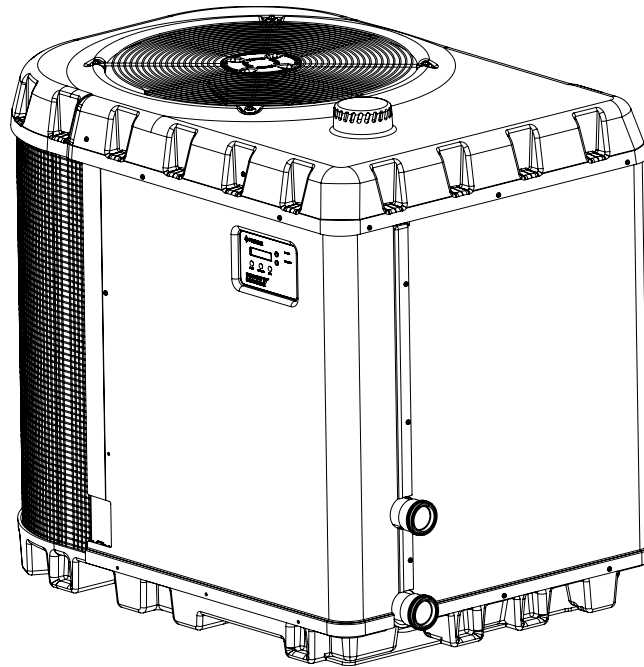

ULTRATEMP ETi™ HYBRID HEATER



ENGLISH

ESPAÑOL

FRANÇAIS

INSTALLATION AND USER'S GUIDE

IMPORTANT SAFETY INSTRUCTIONS
READ AND FOLLOW ALL INSTRUCTIONS
SAVE THESE INSTRUCTIONS



CUSTOMER SERVICE / TECHNICAL SUPPORT

If you have questions about ordering Pentair Aquatic Systems, (“Pentair”) replacement parts, and pool products, please use the following contact information:

Customer Service (8 A.M. to 4:30 P.M. — Eastern and Pacific Times)
Phone: (800) 831-7133
Fax: (800) 284-4151

Web site

Visit www.pentairpool.com or www.staritepool.com to find information about Pentair products.

Technical Support

Sanford, North Carolina (8 A.M. to 4:30 P.M. ET)
Phone: (919) 566-8000
Fax: (919) 566-8920

Moorpark, California (8 A.M. to 4:30 P.M. PT)
Phone: (805) 553-5000 (Ext. 5591)
Fax: (805) 553-5515

TABLE OF CONTENTS

Important Warning and Safety Instructions	ii	Basic Operating Instructions	22
General Information	1	Turning Off Gas to the Heater	22
Heater Introduction	1	Safety Controls	22
Installation Requirements	1	Air Flow Switch (AFS)	23
General Installation Information	1	Water Pressure Switch (WPS)	23
General Features	1	High Limit Switch (HLS) and Automatic Gas Shut-off Switch (AGS)	23
Positioning the Heater	2	Stack Flue Sensor (SFS)	24
Materials Needed for Installation	2	Thermal Fuse (TF)	24
Roof Run-off	2	Float Switch (CFS)	24
Lawn Sprinklers	2	Ignition Module Operation	24
Equipment Pad	3	Operator Menu Tree Guide and Navigation	25
Recommended Clearances	3	Using the Operator Menus	26
Flue Gas Condensation Management	5	Starting and Stopping the Heater	26
Preventative Maintenance	5	Changing the Set Point	26
Condensate Cartridge Service	5	Efficiency Mode Selection	26
Installation	6	Heater Timer	26
Anchor Clamp Installation	6	Remote Mode - Relay	26
System Layout	6	Remote Mode - RS-485 (Serial Cable)	27
Internal Automatic Flow Control Valve	7	Remote Mode - IntelliFlo	27
Water Connections and Plumbing	7	Timers and Delays	27
Heat Pump Drainage Connection	7	Control Panel Alarm Messages	28
Isolation and Check Valves	8	Service Menu Tree Guide and Navigation	29
Manual Bypass Valve	8	Using the Service Menus	29
Pressure Relief Valve (PRV)	8	Eco-Time	30
Multi-Heater Installations	9	Boost Temperature	30
Solar Installations	10	Setting Temperature Scale	30
Water Pressure Switch Adjustment	10	Set Water Temperature Offset	30
Gas Connections	11	Defrost Cycle	30
Gas Line Installation	11	Run Time Counters	31
Checking Gas Pressure Through Gas Control Valve	12	Locking the Control Panel	31
Sediment Traps	12	Maintenance	32
Gas Pressure Testing	12	Water Chemistry	32
Electrical Connections and Wiring	13	Total Alkalinity	32
Wiring Diagram - Input	14	Balancing pH	32
Wiring Diagram - Output	15	Disinfectant Residual	32
Connecting to an Automation System	16	General Maintenance	33
Remote Operation	16	Condensate Drainage	33
Relay Remote Controls	16	Winterizing	34
Connecting to EasyTouch via Heater Spade Terminals	17	Spring Start Up	34
Connecting to EasyTouch via RS-485 Connector	18	Professional Maintenance and Service	34
Pin Configuration for Heater Control Board to EasyTouch	19	Technical Data	35
Connecting EasyTouch to the Heater	19	Electrical Supply - Voltage Requirements	35
Operating the Heater	20	Temperature Resistance Chart	35
Swimming Pool Energy Saving Tips	20	Pressure Chart	36
Control Panel Overview	20	Pressure Drop Curves	36
Sequence of Operation	21	Troubleshooting	37
Pre-Startup	21	Replacement Parts	43
		Heater Parts Breakdown	43
		Parts List - Refrigeration and Outer Shell	44
		Parts List - Gas System	45
		Parts List - Electrical	46
		Parts List - Plumbing	47

IMPORTANT WARNING AND SAFETY INSTRUCTIONS



Important Notice:

This guide provides installation and operation instructions for this hybrid heater. Consult Pentair with any questions regarding this equipment.

Attention Installer: This guide contains important information about the installation, operation and safe use of this product. This information should be given to the owner and/or operator of this equipment after installation or left on or near the heater.

Attention User: This manual contains important information that will help you in operating and maintaining this heater. Please retain it for future reference.

READ AND FOLLOW ALL INSTRUCTIONS SAVE THESE INSTRUCTIONS



This is the safety alert symbol. When you see this symbol on your system or in this manual, look for one of the following signal words and be alert to the potential for personal injury.

⚠ DANGER

Warns about hazards that can cause death, serious personal injury, or major property damage if ignored.

⚠ WARNING

Warns about hazards that may cause death, serious personal injury, or major property damage if ignored.

⚠ CAUTION

Warns about hazards that may or can cause minor personal injury or property damage if ignored.

NOTE

Indicates special instructions not related to hazards.

Carefully read and follow all safety instructions in this manual and on equipment. Keep safety labels in good condition; replace if missing or damaged.

⚠ WARNING

Before installing this product, read and follow all warning notices and instructions which are included.

Failure to follow safety warnings and instructions can result in severe injury, death, or property damage. Call (800) 831-7133 for additional free copies of these instructions.

Codes and Standards

UltraTemp ETi heaters are listed by UL as complying with the latest edition of the "UL Standard for Safety for Heating and Cooling Equipment", UL 1995, CSA C22.2 No. 236 and ANSI Z21.56

Installation must be in accordance with all local codes and/or the latest edition of the National Fuel Gas Code, ANSI Z223.1 and the latest edition of the National Electrical Code, NFPA 70 (US).

Installation in Canada must be in accordance with the latest CAN/CGA-B149.1 or .2 and CSA C22.1 Canadian Electric Code, part 1.

This heater, when installed, must be electrically grounded and bonded in accordance with local codes, or, in absence of local codes, with the National Electrical Code, ANSI/NFPA70 (US) or in Canada in accordance with the Canadian Electric Code, part 1 as applicable.

⚠ WARNING

Do not permit children to use this product.

⚠ WARNING

Improper installation, adjustment, alteration, service or maintenance can cause property damage, personal injury or death. Installation and service must be performed by a qualified installer, service agency or the gas supplier.

⚠ WARNING

RISK OF ELECTRICAL SHOCK OR ELECTROCUTION.

The electrical supply to this product must be installed by a licensed, certified electrician or qualified personnel in accordance with the National Electrical Code and all applicable local codes and ordinances. Improper installation will create an electrical hazard which could result in death or serious injury to pool or spa users, installers, or others due to electrical shock, and may also cause damage to property. Read and follow the specific instructions inside this guide.

⚠ WARNING

For units intended for use in other than single-family dwellings, a clearly labeled emergency switch shall be provided as part of the installation. The switch shall be readily accessible to the occupants and shall be installed at least 5 feet [1.52 m] away, adjacent to, and within sight of the unit.

Consumer Information and Safety

UltraTemp ETi heaters are designed and manufactured to provide safe and reliable service when installed, operated and maintained according to the information in this manual and the installation codes referred to in later sections. Throughout the manual, safety warnings and cautions are identified by the "⚠" symbol. Be sure to read and comply with all of the warnings and cautions.

⚠ WARNING

The U.S. Consumer Product Safety Commission warns that elevated water temperature can be hazardous. See below for water temperature guidelines before setting temperature.

⚠ WARNING

The following "Safety Rules for Hot Tubs" recommended by the U.S. Consumer Product Safety Commission should be observed when using the spa:

1. Spa or hot tub water temperatures should never exceed 104° F. [40° C.]. A temperature of 100° F. [38° C.] is considered safe for a healthy adult. Special caution is suggested for young children. Prolonged immersion in hot water can induce hyperthermia.
2. Drinking of alcoholic beverages before or during spa or hot tub use can cause drowsiness which could lead to unconsciousness and subsequently result in drowning.
3. **Pregnant women beware!** Soaking in water above 100° F. [38° C.] can cause fetal damage during the first three months of pregnancy (which may result in the birth of a brain-damaged or deformed child). Pregnant women should stick to the 100° F. [38° C.] maximum rule.
4. Before entering the spa or hot tub, the user should check the water temperature with an accurate thermometer. Spa or hot tub thermostats may err in regulating water temperatures.
5. Persons with a medical history of heart disease, circulatory problems, diabetes or blood pressure problems should obtain their physician's advice before using spas or hot tubs.
6. Persons taking medication which induce drowsiness, such as tranquilizers, antihistamines or anticoagulants should not use spas or hot tubs.

⚠ WARNING

Should overheating occur or the gas supply fail to shut off, turn off the manual gas control valve to the heater. Do not use this heater if any part has been under water. Immediately call a qualified service technician to inspect the heater and to replace any part of control system and gas control which has been underwater.

⚠ WARNING

Risk of fire, carbon monoxide poisoning, or asphyxiation if exhaust venting system leaks.

Only qualified service technicians should attempt to service the heater, as leakage of exhaust products or flammable gas may result from incorrect servicing.

IMPORTANT WARNING AND SAFETY INSTRUCTIONS

⚠ WARNING The U.S. Consumer Product Safety Commission warns that carbon monoxide is an “invisible killer”. Carbon monoxide is a colorless and odorless gas.

1. Carbon monoxide is produced by burning fuel, including natural gas and propane.
2. Proper installation, operation and maintenance of fuel-burning appliances in the home is the most important factor in reducing carbon monoxide poisoning.
3. Be sure that fuel burning appliances such as heaters are installed by professionals according to manufacturer’s instructions and codes.
4. Always follow the manufacturer’s directions for safe operation.
5. Have the heating system inspected and serviced annually by a trained service technician.
6. Install battery-operated carbon monoxide alarms. The alarms should be certified to the requirements of the most recent UL, IAS, CSA and IAPMO standard for carbon monoxide alarms. Test carbon monoxide alarms regularly and replace dead batteries.

Hyperthermia occurs when the internal temperature of the body reaches a level several degrees above normal body temperature of 98.6° F. [37° C.]. The symptoms of hyperthermia include: drowsiness, lethargy, dizziness, fainting, and an increase in the internal temperature of the body.

The symptoms of hyperthermia include:

1. Unawareness of impending danger.
2. Failure to perceive heat.
3. Failure to recognize the need to leave the spa.
4. Physical inability to exit the spa.
5. Fetal damage in pregnant women.
6. Unconsciousness resulting in danger of drowning.

⚠ DANGER **CARBON MONOXIDE GAS IS DEADLY!** THIS PRODUCT MUST BE INSTALLED AND SERVICED BY A PROFESSIONAL SERVICE TECHNICIAN, QUALIFIED IN POOL HEATER INSTALLATION. Some jurisdictions require that installers be licensed. Check with your local building authority about contractor licensing requirements. Improper installation and/or operation could create carbon monoxide gas and flue gases which could cause serious injury or death. Improper installation and/or operation will void the warranty.

Exhaust from this pool heater contains toxic levels of carbon monoxide, a dangerous, poisonous gas you cannot see or smell. Symptoms of carbon monoxide exposure or poisoning include dizziness, headache, nausea, weakness, sleepiness, muscular twitching, vomiting and inability to think clearly. IF YOU EXPERIENCE ANY OF THE ABOVE SYMPTOMS, IMMEDIATELY TURN OFF THE POOL HEATER, LEAVE THE VICINITY OF THE POOL OR SPA AND GET INTO FRESH AIR IMMEDIATELY. THE POOL HEATER MUST BE THOROUGHLY TESTED BY A GAS PROFESSIONAL BEFORE RESUMING OPERATION.

EXCESSIVE CARBON MONOXIDE EXPOSURE CAN CAUSE BRAIN DAMAGE OR DEATH.

- NEVER use this pool heater indoors.
- NEVER use this pool heater in the home or in partly enclosed areas (such as garages). Install far from open windows, doors, vents and other openings.
- Pentair strongly recommends that exhaust systems be initially and periodically tested for proper operation. This testing can be accomplished by using a hand-held carbon monoxide meter and/or by consulting with a gas professional.

- Pool heaters must be used in conjunction with carbon monoxide detectors installed near the pool heater. The carbon monoxide detectors must be periodically inspected for proper operation so as to insure continued safety. Broken or malfunctioning carbon monoxide detectors must be replaced immediately.

⚠ WARNING This heater is equipped with an unconventional gas control valve that is factory set at a pressure of -.2 inches wc. Improper installation, adjustment, alteration, service or maintenance can cause property damage, personal injury or loss of life. Installation or service must be performed by a qualified installer, service agency or the gas supplier. If this control is replaced, it must be replaced with an identical control. Do not attempt to adjust the gas flow by adjusting the regulator setting.

⚠ WARNING **Risk of fire or explosion from incorrect fuel use.** Do not try to run a heater set up for natural gas on propane gas or vice versa. Only qualified service technicians should attempt to convert heater from one fuel to the other. Do not attempt to alter the rated input or type of gas by changing the orifice. If it is necessary to convert to a different type of gas, consult your Pentair dealer. Serious malfunction of the burner can occur which may result in loss of life. Any additions, changes, or conversions required in order for the appliance to satisfactorily meet the application needs must be made by a Pentair dealer or other qualified agency using factory specified and approved parts. The heater is available for use with natural gas only. It is not designed to operate with any other fuels. Refer to the nameplate for the type of gas the heater is equipped to use. Use only fuel for which the heater is designed.

⚠ WARNING **Risk of fire or explosion from flammable vapors.** Do not store gasoline, cleaning fluids, varnishes, paints, or other volatile flammable liquids near heater.

⚠ WARNING **Risk of explosion if unit is installed near propane gas storage.** Propane (LP) gas is heavier than air. Consult local codes and fire protection authorities about specific installation requirements and restrictions. Locate the heater away from propane gas storage and filling equipment as specified by the Standard for the Storage and Handling of Liquefied Petroleum Gases, CAN/CSA B149.2 (latest edition) or ANSI/NFPA 58 (latest edition).

⚠ CAUTION Combustion air contaminated by corrosive chemical fumes can damage the heater and will void the warranty.

⚠ CAUTION Label all wires prior to disconnection when servicing controls. Wiring errors can cause improper and dangerous operation. Wiring errors can also destroy the control board.

- Connect heater to 240 Volt, 60 Hz., Single Phase power only.
- Verify proper operation after servicing.
- Do not allow children to play on or around heater or associated equipment.
- Never allow children to use the pool or spa without adult supervision.
- Read and follow other safety information contained in this manual prior to operating this pool heater.

General Specifications

Installation Location Certified for Use: OUTDOOR USE ONLY. Failure to provide the proper clearances outlined on page 3-4 will lower the performance of the heat pump and void the warranty.

Water Pipe/Heater Connection: Plastic 2” PVC (Unions included)

Flow Rate:

Maximum 120 gpm [456 lpm] - If system flow rate exceeds 120 gpm, a bypass valve is required.

Minimum 30 gpm [110 lpm].

Maximum Working Water Pressure 50 psi

For Electrical Supply and Voltage Requirements, refer to the table on page 35.

GENERAL INFORMATION

Heater Introduction

Thank you for choosing the UltraTemp ETi™ Hybrid Heater. Proper installation and service of your new heating system, and correct chemical maintenance of the water will ensure years of heater operation. The UltraTemp ETi heater is equipped with Pentair's advanced heater technology which includes a heat pump and a pool heater, with a multifunction temperature controller to continuously monitor the hybrid heater for proper operation. These heaters are designed with direct spark ignition (DSI) for on demand heat, which eliminates the need for a standing pilot.

The heater is certified as complying with the Standard for Gas Fired Pool Heaters, ANSI Z21.56/CSA 4.7, and with the Standard for Heating and Cooling Equipment, UL 1995/CSA C22.2 No. 236-15. This heater is intended for use in heating fresh water swimming pools or spas.

Installation Requirements

Correct installation is required to assure safe operation. The requirements for Pentair heaters include the following:

- Dimensions for critical connections (see **Figure 1**, page 2).
- Field assembly (if required).
- Appropriate site location and clearances (pages 2-4).
- Proper electrical wiring (pages 14-16).
- Adequate water flow (see *General Specifications*, page iii).

This manual provides the information needed to meet these requirements. Review all application and installation procedures completely before continuing the installation.

General Installation Information

1. Installation and service must be performed by a qualified installer or service agency, and must conform to all national, state, and local codes.
2. Heaters get electrical power from an external source and provide a dual electronic thermostat control system for pool/spa combinations or preheat convenience.
3. The heater is designed for the heating of chlorine, bromine or salt system swimming pools and spas. It should NOT be used as a space heating boiler, or general purpose water heater.
4. The heater should be located in an area where leakage of the heater or connections will not result in damage to the area adjacent to the heater or to the structure. When such locations cannot be avoided, it is recommended that a suitable drain pan, adequately drained, be installed under the heater. The pan must not restrict air flow.

5. The heater is designed for outdoor operation in non-freezing conditions only. If installed for seasonal use in freezing climates, the heater must be winterized to avoid freeze damage. See *Winterizing*, page 34.

General Features

- Dual digital thermostats offer precise temperature control to maintain the desired separate water temperatures in pool/spa combinations without overheating or wasting energy.
- Long-life corrosion resistant composite plastic cabinet stands up to severe climates and pool chemicals.
- 100% pure titanium heat pump and direct-fire gas heat exchangers assure corrosion-free performance for extra long life.
- Self-diagnostic control panel monitors and troubleshoots heater operations to ensure safe, dependable operation.
- Automatic Defrost feature senses refrigerant temperature and prevents the heat pump evaporator coil from freezing, allowing the heater to operate at even lower temperatures.
- Compatible with all automated control packages. RS-485 communication compatible with EasyTouch® Control Systems.
- Thermostatic expansion valve (TXV) controls refrigerant flow for optimum efficiency and BTU output over a wider operating range.
- Elevated base pan for positive drainage of condensation.
- 2-inch plumbing connections for easy installation.
- Separate isolated electrical compartment prevents internal corrosion, extends heater life.
- Adjustable timer allows the operator to set the heater to run for a predetermined time. Incremental by 10 minutes to a maximum of 99 hours.
- An extensive list of operational conditions, alarms and water temperatures are logged on the control board. This information is available for the user to track performance and troubleshoot issues.
- Four unique operating modes: Heat Pump only, Gas Heater only, Dual and Hybrid.

POSITIONING THE HEATER

⚠ WARNING

CARBON MONOXIDE GAS IS DEADLY – Exhaust from this pool heater contains carbon monoxide, a dangerous, poisonous gas you cannot see or smell. Symptoms of carbon monoxide exposure or poisoning include dizziness, headache, nausea, weakness, sleepiness, muscular twitching, vomiting and inability to think clearly. IF YOU EXPERIENCE ANY OF THE ABOVE SYMPTOMS, IMMEDIATELY TURN OFF THE POOL HEATER, LEAVE THE VICINITY OF THE POOL OR SPA AND GET INTO FRESH AIR IMMEDIATELY. THE POOL HEATER MUST BE THOROUGHLY TESTED BY A GAS PROFESSIONAL BEFORE RESUMING OPERATION. **EXCESSIVE CARBON MONOXIDE EXPOSURE CAN CAUSE BRAIN DAMAGE OR DEATH.**

⚠ CAUTION

When pool equipment is located below the pool surface, a leak from any component can cause large scale water loss or flooding. Pentair Water Pool and Spa, Inc. can not be responsible for such water loss or flooding which may cause damage to property or to the product. Avoid placing the heater in locations where it can cause damage by water or condensate leakage. If this is not possible, provide a suitable drain pan to catch and divert any leakage.

Only a qualified service person should install the UltraTemp ETi™ Hybrid Heater. Before installing this product, refer to the *Important Warning and Safety Instructions* on page ii.

In the United States, installation must be in accordance with local codes and the most recent edition of the National Fuel Gas Code, ANSI Z223.1/NFPA-54. In Canada, install the heater in accordance with local codes and the most recent edition of the Natural Gas and Propane Installation Code, CAN/CSA B149.1.

Materials Needed for Installation

The following items are needed and are to be supplied by the installer for all heater installations:

1. Plumbing connections (2-inch).
2. Level surface for proper drainage.
3. Suitable electrical supply line. See rating plate on unit for electrical specifications. A junction box is not needed at the heater; connections are made inside of the heater electrical compartment. Conduit may be attached directly to the heater jacket.
4. Electric cutout switch that will interrupt all power to the unit. This switch must be within line of sight of the heater. Check local codes for requirements.
5. Watertight conduit to run the electrical supply line.
6. Suitable gas supply line with sediment trap (see **Table 1** on page 11 for sizing requirements).

Roof Run-off

Make sure the heater is not located where large amounts of water may run-off from a roof into the unit.

Sharp sloping roofs without gutters will allow massive amounts of rain water, mixed with debris from the roof to be forced through the unit. A gutter or down spout may be needed to protect the heater.

Lawn Sprinklers

Avoid placing lawn sprinkler near the heater - they can spray water into the heater and void the warranty. Be sure to direct any spraying water away from the heater. Note the wind direction to be sure water from sprinklers is not blown toward the heater. Sprinkler heads can produce high water pressure and spray at an angle, different from typical rain and humid weather. Also, sprinklers connected to a well water system can cause mineral build up on the evaporator coils and electronics. Salt water can also be an issue if located near the coast.

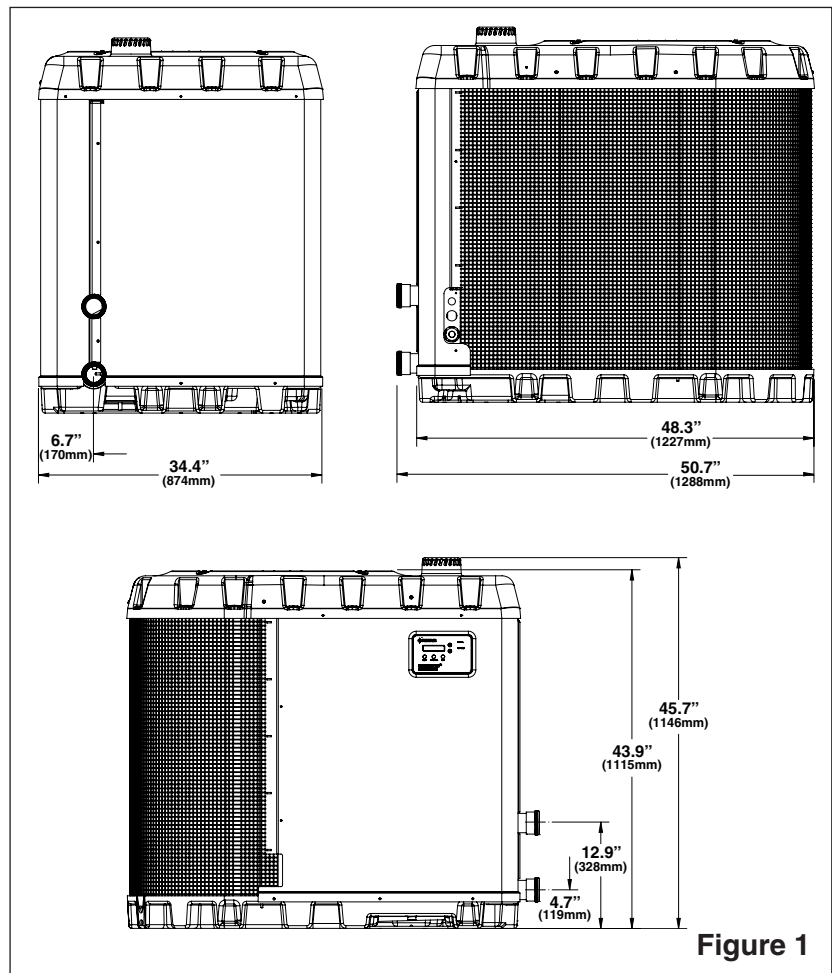

Figure 1

Equipment Pad

For proper drainage of condensation and rain water, place the heater on a flat slightly pitched surface, such as a concrete or fabricated slab (pad).

If possible, place the pad at the same level or slightly higher than the filter system equipment pad.

The equipment pad should also be in an area where leaves or other combustible debris will not collect on or around the heater.

Note: Be sure that the pad is pitched not more than 1/4 in. per foot in any direction as needed for runoff.

Note: The equipment pad should be no less than 4 in. (100 mm) thick.

Recommended Clearances

All criteria given in the following sections reflect minimum clearances. However, each installation must also be evaluated, taking into account the prevailing local conditions such as proximity and height of walls, and proximity to public access areas.

The UltraTemp ETi™ Hybrid Heater must be placed to provide clearances on all sides for maintenance and inspection. Refer to **Figure 2** for a visual representation of the proper clearances.

1. At least 30 inches [610 mm] of clearance is required on both the plumbing and control panel side of the heater. This will provide necessary room for servicing.
2. At least 12 inches [305 mm] of clearance must be available on all the other sides of the heater to allow for proper air flow.
3. If the heater is to be installed under a cover or under a vertical overhang, the unit must have a minimum of five (5) feet [1.5 m] clearance from the top of the heater.

4. Install a minimum of five (5) feet [1.52 m] from the inside wall of the pool or spa unless the heater is separated from the pool or spa by a five (5) foot [1.52 m] high solid fence or other permanent barrier. Canadian installations require a minimum of three (3) meters [9.84 ft] from pool water.
5. Install heater a minimum of 12 in. [305 mm] from the wall of the house.
6. For minimum exhaust vent clearances, see **Figure 3** on next page.

Note: In Canada, the heater must be installed with the top of the vent at least 10 ft. (3 m) below, or to either side of, any opening into a building.

CAUTION

If installing the heater next to or near an air conditioning unit, heater or another gas pool heater, allow a minimum of 36 in. (91.4 cm) between the unit and the heater.

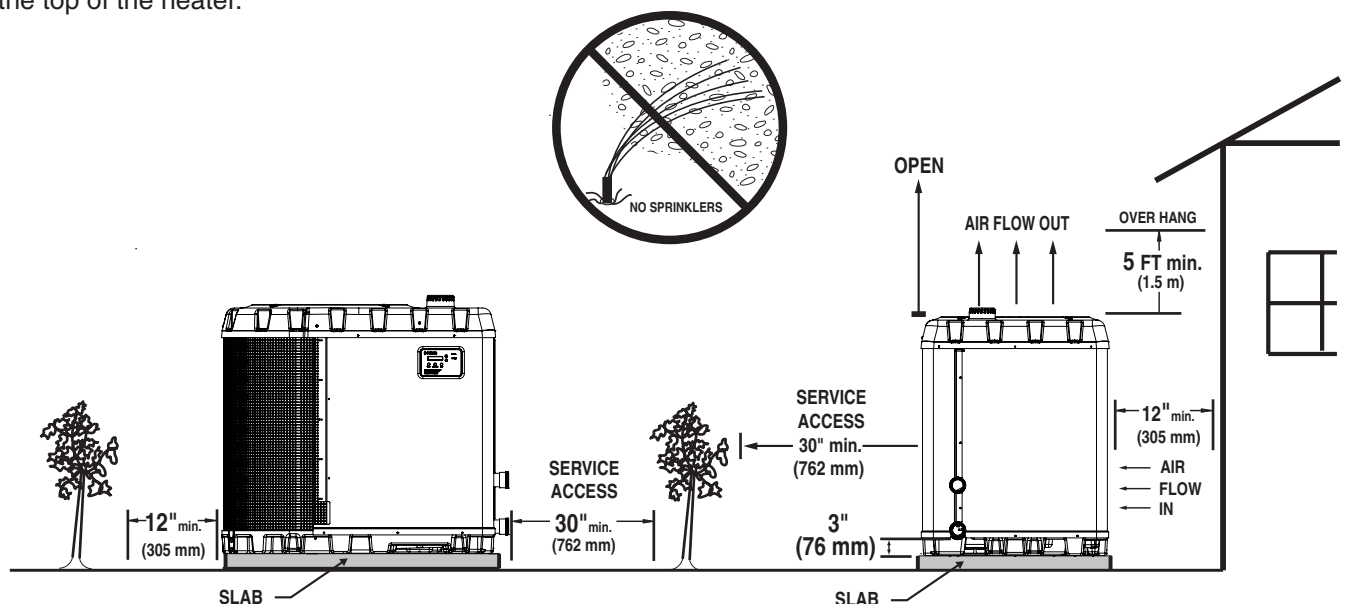
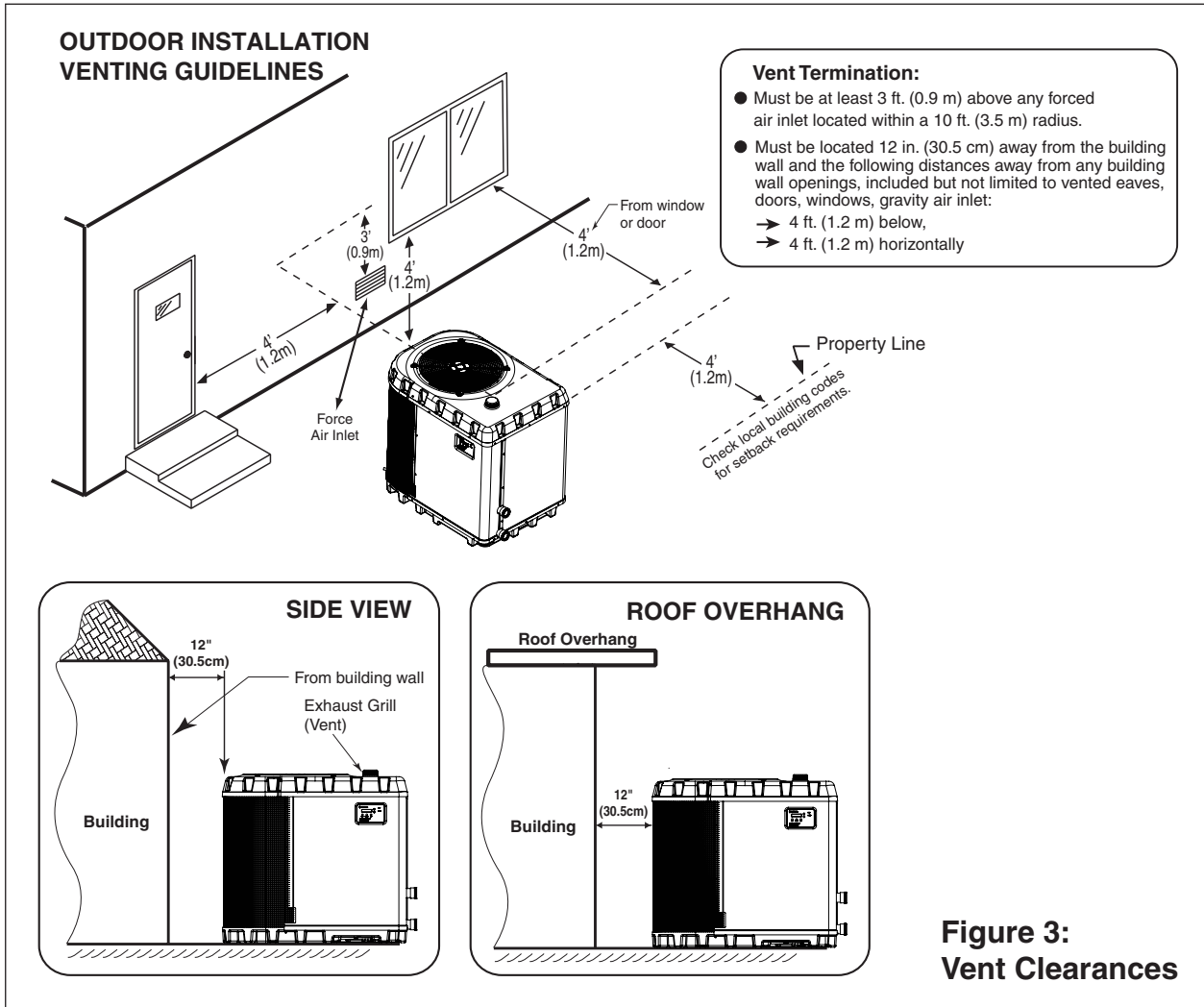

Figure 2: Heater Clearances

Recommended Clearances (cont.)



**Figure 3:
Vent Clearances**

Flue Gas Condensation Management

The UltraTemp ETi™ Hybrid Heater is a condensing appliance. The flue gases will produce condensate while in operation and must be drained correctly.

The condensate pH level is between 3.1 and 4.2. Pentair recommends neutralizing the condensate to avoid potential damage over time to the drainage system, and to comply with local water authorities where applicable. To neutralize the condensate, use the Condensate Neutralizer Cartridge provided with the heater. The condensate drain must be installed so as to prevent accumulation of condensate. When a condensate pump is not used, the tubing must continuously slope downward toward the drain with no spiraling.

Note: Consult local codes for treated condensate disposal method.

WARNING DO NOT allow the exhaust flue gases to vent through the neutralizer. All condensate drains MUST have a trap to prevent flue gas leakage. Flue gas leakage can cause personal injury or death from carbon monoxide. Check with local authorities for regulations regarding discharge of condensate to the drain sewer system.

CAUTION pH levels of 5.0 and below may harm some floor drains and/or pipes, particularly those that are metal. Ensure that the drain, drainpipe, and anything that will come in contact with the condensate can withstand the acidity. Damage caused by failure to install a neutralizer kit or to adequately treat condensate will not be the manufacturer's responsibility.

Preventative Maintenance

Annual condensate assembly inspection: Inspect the internal tubing top for any dirt or particles that could collect and clog the condensate neutralizer cartridge.

Based on operating conditions, algae buildup in the condensate cartridge may occur. Excessive algae buildup can prevent proper condensate drainage

CAUTION DO NOT expose the condensate cartridge to freezing temperatures without draining. This could damage the cartridge. See page 34 for proper Winterizing instructions.

Condensate Cartridge Service

If the control board reads "REPLACE CNC", check pH of condensate liquid. If the pH is below 5.0, replace the condensate cartridge with a Condensate Neutralizer Kit, (P/N 475954).

If the pH is not known, replace the condensate cartridge when the control board recommends.

To clear this alarm, press the DOWN arrow and MODE button simultaneously. The alarm may take a few moments to clear after the buttons are pressed.

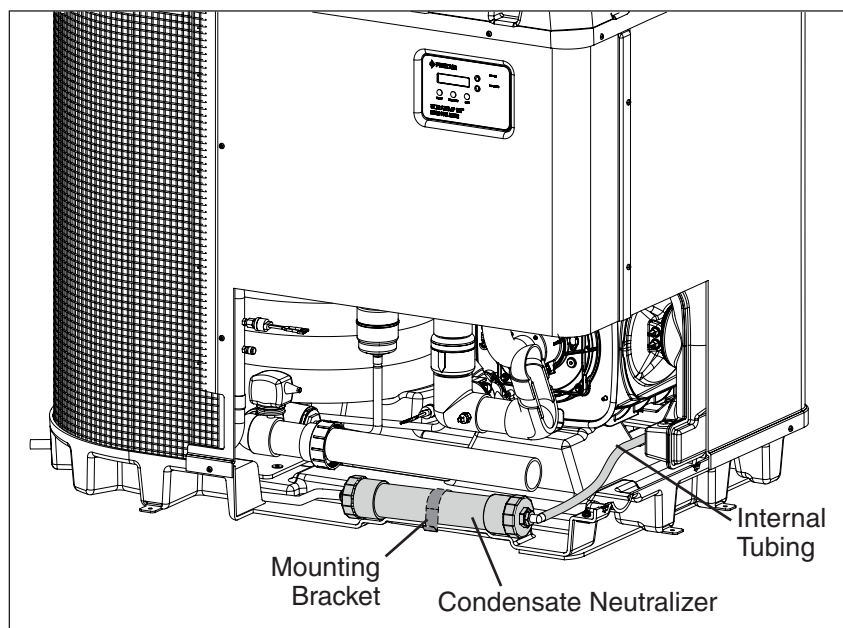

Figure 4: Condensate Neutralizer Cartridge Installed in the Heater Base

INSTALLATION

The installation instructions contained in this manual are designed for use by qualified personnel only, trained especially for installation of this type of heating equipment and related components. Some states require installation and repair by licensed personnel. If this applies in your state, be sure your contractor possesses the appropriate license.

Anchor Clamp Installation

Installation of the anchor clamps is recommended in all installations. Installation of the anchor clamps is required in Florida (see Florida Building Code 301.13).

Anchor clamps hold the heater to the equipment pad in order to withstand high winds caused during extreme weather (i.e. hurricanes).

Note: Anchor clamps are included with the heater. They can be found attached to the wood pallet that the heater is shipped with.

To install the anchor clamps:

1. Be sure the heater is in its permanent location on the equipment pad.
2. Place the clamps at the base of the heater in the eight (8) locations, shown in **Figure 5**.

Note: Bolts and washers are not included with the heater. The installer must provide 1/4" x 2-1/4" stainless steel anchor bolts and the appropriate size washers to mount the clamp to the concrete equipment pad. Be sure to check local codes.

3. Fit the hook of each clamp into the slots in the base panel of the heater.
4. Mark the position of the hole in each clamp on the equipment pad.
5. Use a masonry drill bit and drill a hole in the cement with a diameter as determined by the concrete anchor, at each of the marks on the concrete equipment pad. The hole should be approximately 2-3/4" (7 cm.) deep.
6. Position the anchor clamps so that the holes in the clamps are over the drilled holes in the equipment pad and the other end of the clamp is secured inside of the heater base.
7. Insert an anchor bolt through each clamp into the anchor and tighten to secure the clamp and heater to the equipment pad. See **Figure 6**.

Note: Anchor bolts should be tightened to around four (4) ft/lbs.

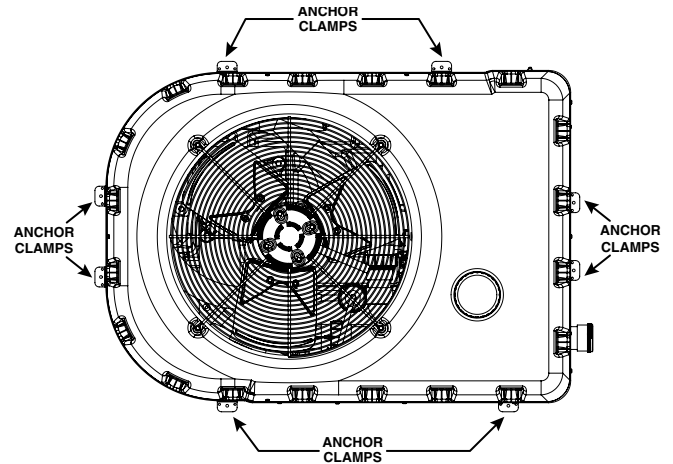
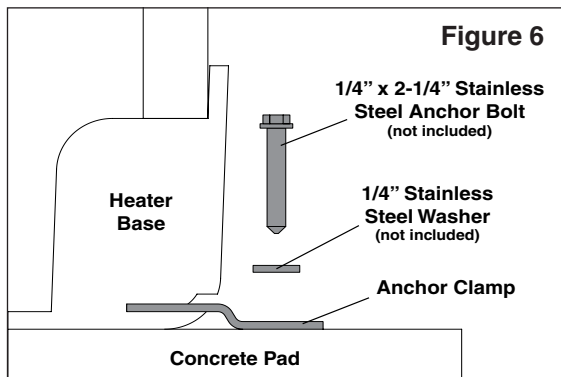

Figure 5: Anchor Clamp Locations

System Layout

The image below shows the standard plumbing layout with a single UltraTemp ETi™ Hybrid Heater unit. Follow **Figure 7** from right to left for the standard plumbing sequence.

Arrangement of pool system components (other than the standard plumbing image below), and the location of the heater (above or below the pool water surface) can affect the operation of the heater's water pressure switch.

The pressure switch can be adjusted to accommodate this effect if the heater water connections are no more than six (6) feet [1.82 m] below the pool water surface.

See instructions for pressure switch adjustment on pages 10-11. If the heater is installed outside of this range, an external water flow switch may need to be installed in the plumbing upstream of the heater.

Note: Be advised that when pool equipment is located below the pool surface a leak can result in large-scale water loss or flooding. Pentair is not responsible for such water loss or flooding or damage.

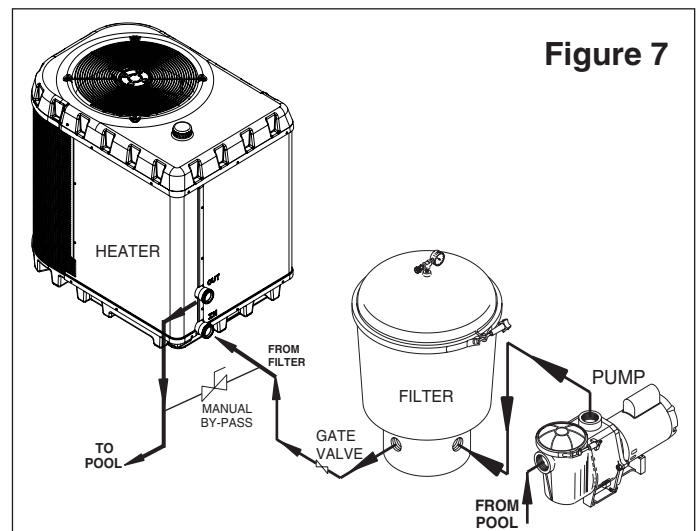

Figure 7

Internal Automatic Flow Control Valves

The inlet/outlet header of the UltraTemp ETi™ Hybrid Heater comes equipped with an internal water management system with two automatic flow control valves. The automatic flow control valves maintain the proper flow through the heater at rates up to 120 gpm (454 lpm). If the filter system flow rate is higher than 120 gpm (454 lpm), install a manual bypass valve.

Note: Be advised that if your circulation pump is over 2 HP or if the total flow exceeds 120 gpm (454 lpm), you will have to add an external bypass valve. Excess water flow will damage the heat exchanger.

Water Connections and Plumbing

CAUTION Always be sure that flow requirements and pool water turnover rates can be maintained with the installation of additional equipment and plumbing restrictions.

2 in. Quick Connect fittings have been installed on the water inlet and outlet connections. Filtered cool water is plumbed to the heater.

Plastic piping (PVC Schedule 40) should be connected to the heater. The unions, provided with the unit, accept 2 in. PVC pipe.

The heater requires proper water flow and pressure for its operation. To properly operate the heater requires a flow rate of at least 30 GPM, but optimal performance is achieved at 50 GPM. The maximum working pressure for the system is 50 PSI.

See **Figure 8** for the recommended installation. The filter pump discharges to the filter, the filter discharges to the heater, and the heater discharges directly to the pool or spa.

A manual bypass valve should be installed before the heater when the pump flow exceeds 120 GPM (454 LPM).

Make sure that the outlet plumbing from the heater contains no shut-off valves or other flow restrictions that could prevent flow through the heater (except for pool installations as noted below, or winterizing valves where needed). To switch flow between the pool and spa, use a diverter valve. Do not use any valve that can shut off the flow.

Install the chemical feeder downstream of the heater. Install a chemical resistant one-way check valve between the heater and the chemical feeder to prevent back-siphoning through the heater when the pump is off.

Note: If the heater is plumbed in backwards, it will cycle continuously. Make sure piping from filter is not reversed when installing heater.

Connect the heater directly to 2 in. PVC pipe, using the provided unions. Heat sinks are not required. The low thermal mass of the heater will prevent overheating of the piping connected to the pump even if the heater shuts down unexpectedly.

Occasionally a two-speed pump will not develop enough pressure on the low speed to operate the heater. In this case, run the pump at high speed only to operate the heater. If this does not solve the problem, do not try to run the heater. Instead, correct the installation.

Do not operate the heater while an automatic pool cleaner is also operating. If the circulation pump suction is plugged (for example by leaves), there may not be adequate flow to the heater. Do not rely on the pressure switch in this case.

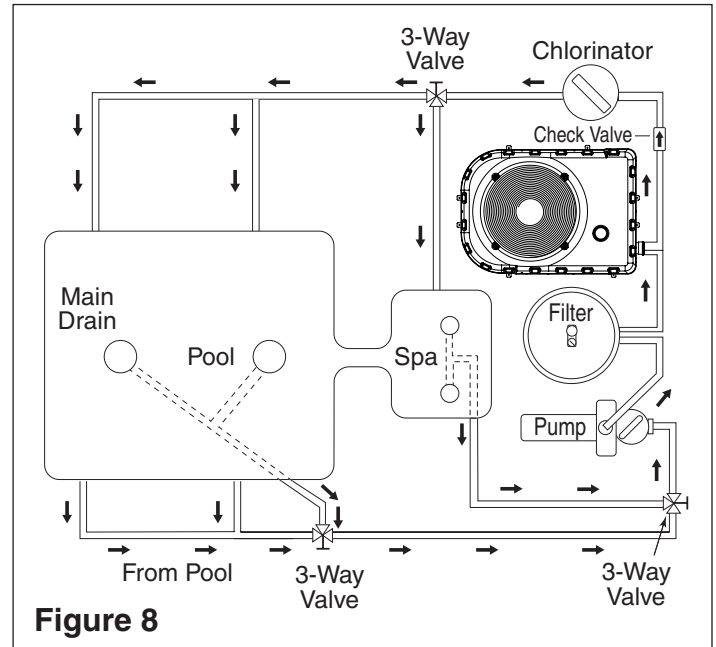

Figure 8

Heat Pump Drainage Connection

Condensation (water) will be produced while the heat pump is in operation. The heater base is designed to allow the condensation to exit through the bottom drain port when the unit is running.

Before operating the heater for the first time, the drain hose barb must be installed into the threaded drain port located in the base of the heater.

To install the Drain Hose Barb and Drain Hose:

1. Thread the drain hose barb into the threaded drainage port in the base of the heater. See **Figure 9**.
2. Connect a 5/8" garden hose to the hose barb.
3. Ensure the end of the garden hose is positioned so that drainage will flow away from the heater and equipment pad.

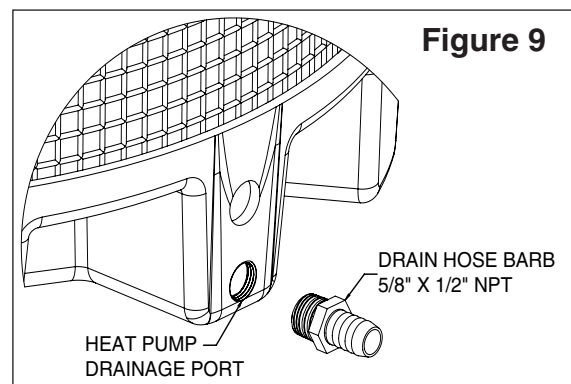

Figure 9

Isolation and Check Valves

When any equipment is located below the surface of the pool or spa, valves should be placed in the circulation piping system to isolate the equipment from the pool or spa. Check valves are recommended to prevent back-siphoning. Back-siphoning is most likely to occur when the pump stops, creating a pressure-suction differential. Do NOT sanitize the pool by putting chlorine tablets or sticks into the skimmer(s). When the pump is off, this will cause a high concentration of chlorine to enter the heater, which could cause corrosion damage to the heat exchanger.

CAUTION

Exercise care when installing chemical feeders so as to not allow back siphoning of chemical into the heater, filters or pump. When chemical feeders are installed in the circulation of the piping system, make sure the feeder outlet line is downstream of the heater, and is equipped with a positive seal noncorrosive Check Valve, (P/N R172288), between the feeder and heater.

Manual By-Pass Valve

Where the water flow rate exceeds the maximum 120 GPM, a manual bypass should be installed. After installing the valve, adjust the valve to bring the flow rate within the acceptable range. Then remove the valve handle or lock it in place to avoid tampering.

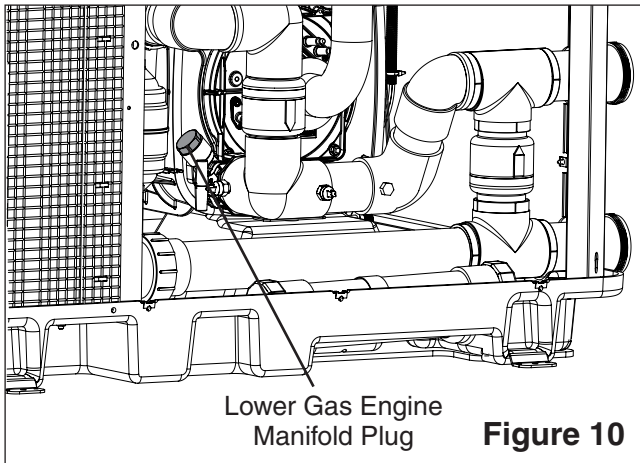

Lower Gas Engine
Manifold Plug **Figure 10**

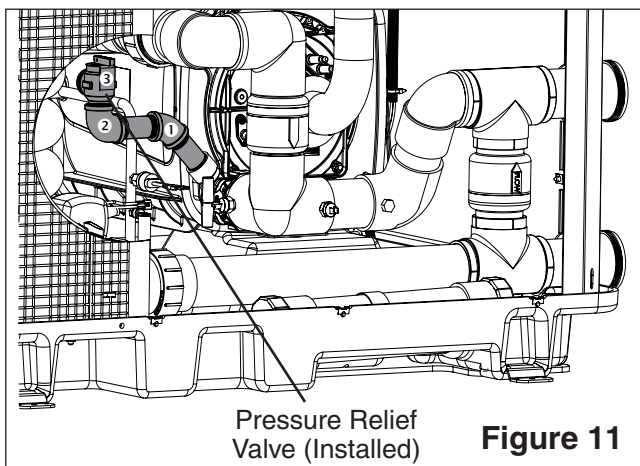

Pressure Relief
Valve (Installed) **Figure 11**

Pressure Relief Valve (PRV)

WARNING

Explosion hazard! Any heater installed with restrictive devices in the piping system downstream from the heater, (including check valves, isolation valves, flow nozzles, or therapeutic pool valving), must have a relief valve installed as described in this section.

Canadian code, and some U.S. local codes, may require installation of a Pressure Relief Valve (PRV). Purchase and install a Hybrid Pressure Relief Valve Kit (P/N 475943) complying with the ANSI/ASME Boiler and Pressure Vessel Code, having a capacity equal to the Btu/hr rating of the heater.

Note: The relief pressure of the valve MUST NOT EXCEED 50 PSI. The relief valve must be installed vertically.

To install the pressure relief valve:

Note: Be sure to use threaded seal tape (PTFE) or equivalent, on all threaded metal pipe connections.

1. Remove the heater service panel.
2. Remove the lower gas engine manifold 3/4" brass plug. See **Figure 10**.
3. Thread the Schedule 40 brass pipe and 45-degree elbow [1], included in the PRV kit, into the lower gas engine manifold. The elbow should be oriented so that the elbow's female thread is horizontal. See **Figure 11**.
4. Thread the second Schedule 40 brass pipe and 90-degree elbow [2] into the 45-degree elbow [1]. Ensure that the open end of the 90-degree elbow is oriented vertically. See **Figure 11**.
5. Install the Pentair pressure relief valve (P/N 072138), included in the PRV kit, or an equivalent 50 PSI 3/4" ASME-Type IV relief valve [3] into the 90-degree elbow [1]. See **Figure 11**.
Note: Ensure the relief valve is oriented so the outlet is facing straight into the heater and will not direct towards the service panel.
6. Inspect the valve annually to ensure proper operation. Replace if improper operation is determined.

Multi-Heater Installations

All plumbing on multiple heater installations must be done in parallel (see **Figure 12** and **13** below). An equal flow of water to each heater is important for optimum operation.

Note: It may be necessary to adjust the water pressure switch if a unit is installed below the water level. Refer to page 10-11 for details on when and how to adjust the pressure switch.

Each heater in a multiple unit installation allows a maximum flow rate of 100 gpm (380 lpm) and requires a minimum of 30 gpm (110 lpm).

ENGLISH

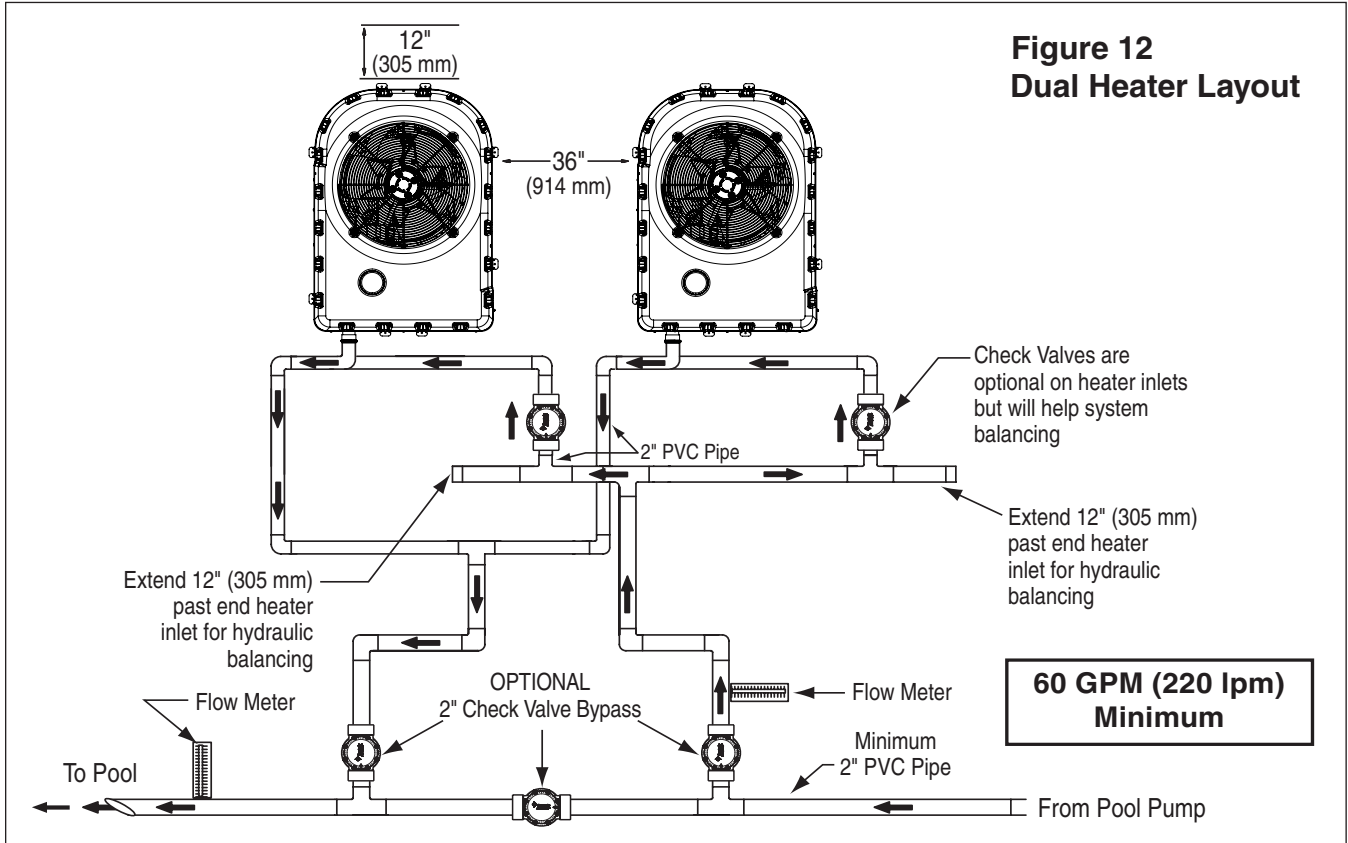

Figure 12
Dual Heater Layout

60 GPM (220 lpm)
Minimum

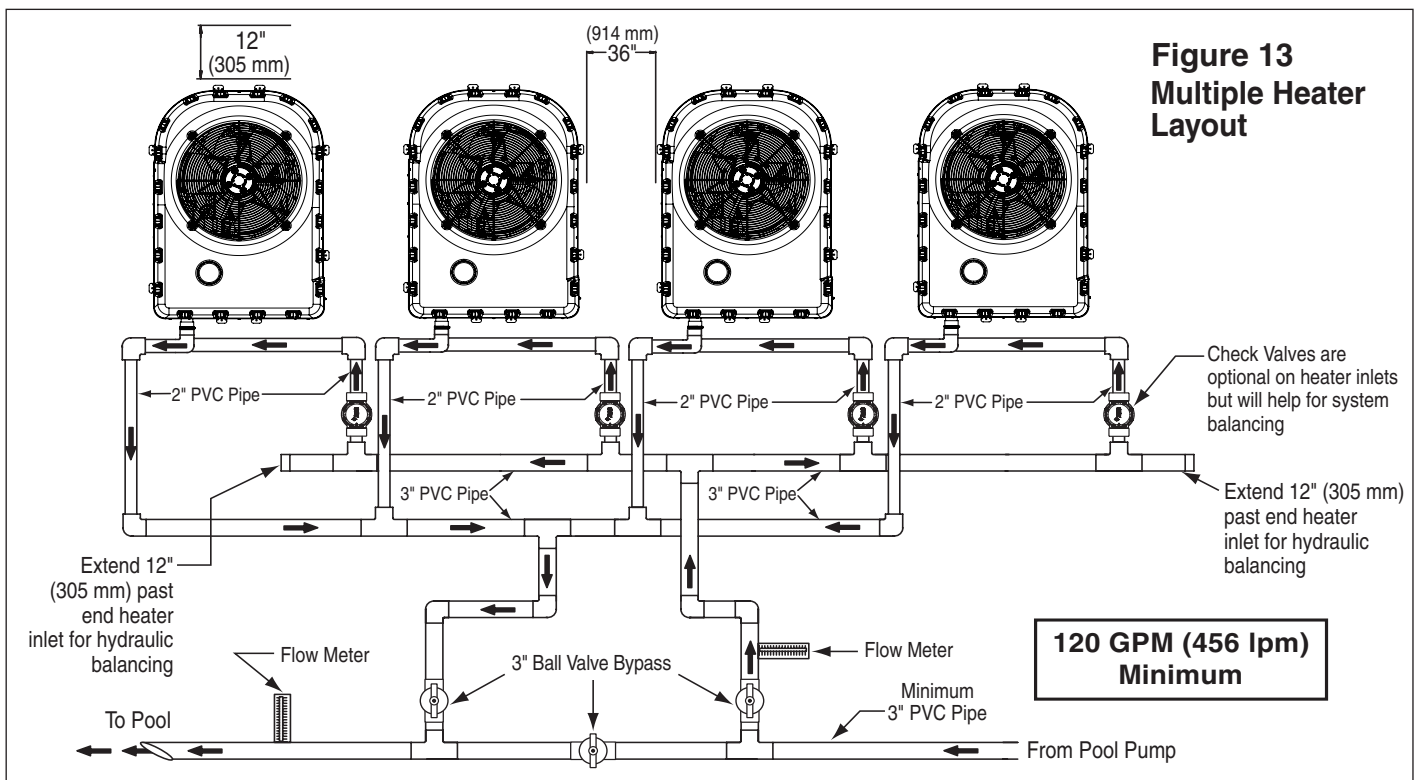

Figure 13
Multiple Heater Layout

120 GPM (456 lpm)
Minimum

Solar Installations

The UltraTemp ETi™ Hybrid Heater can be used in combination with other heating schemes such as solar. All heat sources must be plumbed in series to work correctly and efficiently.

A recommended plumbing layout for a heater-solar combination heating system for a pool / spa combination is shown below (**Figure 14**). Your system may not contain all of these components, but the basic plumbing will apply by eliminating the component in the illustration that is not a part of your system.

Note: Water temperatures produced by supplemental heating sources, such as solar, are not regulated or controlled by the heater and may exceed the maximum temperature allowed.

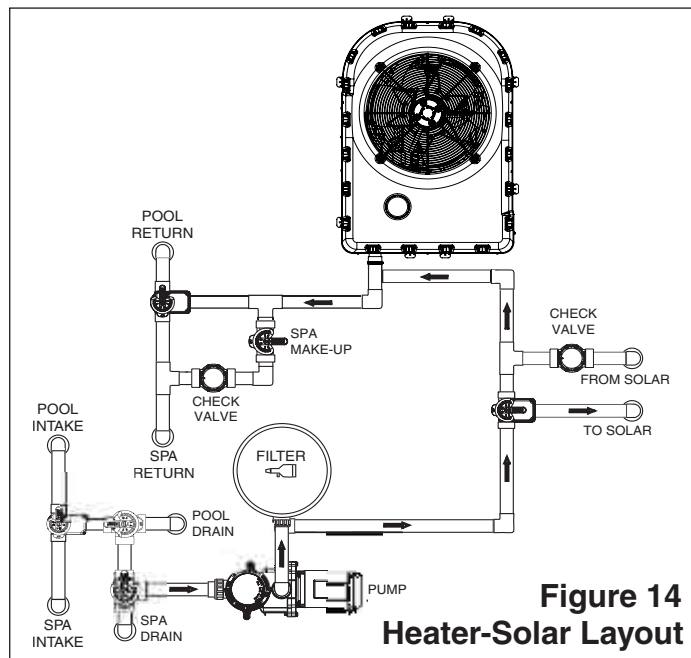

Figure 14
Heater-Solar Layout

Turn star wheel **clockwise** to raise pressure set point

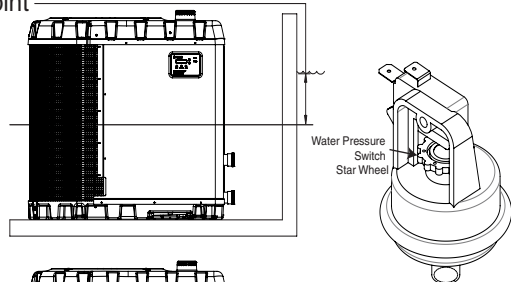

Figure 15

A reference scale is on the back of pressure switch

Turn star wheel **counterclockwise** to lower pressure set point

Water Pressure Switch Adjustment

CAUTION The water pressure switch should be adjusted to turn the heater off when the pump is off. Setting the switch to close at too low of a flow can damage the appliance. Adjust the switch to turn the heater off, not on.

The pressure switch is preset at the factory for activation at 6 psi [41.4 kPa]. This factory setting works for most basic installations. Only adjust the water pressure switch if the heater does not operate **when the proper flow is applied to unit** or if the heater does not shut off when the filter pump is off. Occasionally, unusual plumbing configurations or necessary restrictions in the plumbing may cause pressure sensing problems. In these rare situations, the plumbing system configuration may require adjustment of the water pressure switch.

Adjustment of the pressure switch may be necessary if any part of the filter system piping is 3 feet [0.91 m] or more above the top of the heater.

In general, if the heater is installed more than 6 feet [1.83 m] below the pool surface, an external water flow switch must be added to the plumbing system.

On some installations, the piping from the heater to the pool is very short. The back pressure could be too low to trigger the pressure switch. If this happens, install a directional fitting or elbow where the return line enters the pool. This will increase back pressure for the heater to operate properly. Be sure to check that the system flow is above the minimum requirement of 30 gpm (110 lpm) after the directional fitting installation.

Be sure the pool filter is clean before making any pressure switch adjustment: A dirty filter will restrict the water flow and the pressure switch cannot be adjusted properly.

To adjust the pressure switch:

The following adjustment is for installations where the heater is below pool water level.

1. Be sure that all valves in the system are set to allow water flow through the heater. Start the filter pump.
2. Set the heater temperature above the actual temperature to call for heat. Turn the heater ON.
3. Once the heater is running, turn off the filter pump. The heater should turn off immediately.
4. If the heater continues to operate when the filter pump is off, then the water pressure switch needs to be adjusted.
5. Remove the heater's left front panel and remove remaining right front panel. The water pressure switch is located in the water plumbing in the lower corner of the heater.
6. Slowly rotate the adjustment wheel on the water pressure switch in a counterclockwise direction until the "LOW WATER FLOW" Alarm shows on the LCD, the red SERVICE light turns ON, and the heater stops. See **Figure 15**.

Water Pressure Switch Adjustment (cont.)

7. Check the setting of the water pressure switch by starting and stopping the filter pump and checking the control panel and operation of the heater between each flow change.
8. If the water pressure switch cannot be adjusted to accommodate the conditions listed above, an external flow switch must be added to the plumbing system to ensure that the heater will not operate without the proper flow through the heat exchanger.

The following adjustment is for installations where the heater is **above pool water level**.

1. Be sure that all valves in the system are set to allow water flow through the heater. Start the filter pump.
2. Set the heater temperature above the actual temperature to call for heat. Turn the heater ON.
3. If the LCD shows a “LOW WATER FLOW” Alarm and red SERVICE light is present then the water pressure switch needs to be adjusted.
4. Remove the UltraTemp ETi™ Hybrid Heater’s left front panel and remove remaining right front panel. The water pressure switch is located in the water plumbing in the lower corner of the heater.
5. Slowly rotate the adjustment wheel on the water pressure switch in a counterclockwise direction until the “LOW WATER FLOW” Alarm and red SERVICE light vanish, time delay countdown will start.
6. Once the heater is running, turn off the filter pump. The heater should turn off immediately.
7. If the heater continues to operate when the filter pump is off, turn the adjustment wheel on the water pressure switch in a clockwise direction until the “LOW WATER FLOW” Alarm shows on the LCD, the red SERVICE light turns ON, and the heater stops.
8. Check the setting of the water pressure switch by starting and stopping the filter pump and checking the control panel and operation of the heater between each flow change.
9. If the water pressure switch cannot be adjusted to accommodate the conditions listed above, an external flow switch must be added to the plumbing system to ensure that the heater will not operate without the proper flow through the heat exchanger.

Gas Connections



The use of Flexible Gas Connectors (FLEX) is NOT recommended unless they are properly sized according to the supplier recommendations for the heater rating. In all cases, the connectors must be bonded to the electrical service grounding point or, when provided, the lightning protection grounding point according to the latest edition of the National Fuel Gas Code.

Gas Line Installation

When sizing gas lines, calculate three (3) additional feet of straight pipe for every elbow used. When installing the gas line, avoid getting dirt, grease or other foreign material in the pipe as this may cause damage to the gas valve, which may result in heater failure.

The gas meter should be checked to make sure that it will supply enough gas to the heater and any other appliances that may be used on the same meter. The gas line from the meter will usually be of a larger size than the gas valve supplied with the heater. Therefore a reduction of the connecting gas pipe will be necessary. Make this reduction as close to the heater as possible.

The heater requires a gas supply of no less than 4 in. (10.2 cm) wc, and no more than 10.5 in. (27 cm) wc for natural gas (no more than 14 in. [36cm] for propane gas). Gas supply pressures outside of this range may result in improper burner operation. A minimum flowing or dynamic inlet pressure (while the heater is running) of 4 in (10.2 cm) wc is required to maintain input rating with no more than a 2 in. pressure drop between static and dynamic. The gas supply must be installed in accordance with the National Fuel Gas Code, ANSI Z223.1, or standard CSA B149.1, Natural Gas and Propane Installation Codes, as applicable and all applicable local codes. Install a manual shut-off valve and a sediment trap and union located outside the heater panels, see **Figure 17** on the next page. Do not use a restrictive gas cock. The following minimum gas pipe sizes are recommended for natural gas supply piping, see **Table 1** below. Check for compliance with local codes.

The heater and any other gas appliances must be disconnected from the gas supply piping system during any pressure testing on that system, (greater than 1/2 PSI). The heater and its gas connection must be leak tested before placing the heater in operation. Do not use flame to test the gas line. Use soapy water or another nonflammable method.

Note: A manual main shut-off valve for the heater must be installed externally.



Do NOT install the gas line union inside the heater cabinet. This will void the warranty.

MAXIMUM EQUIVALENT PIPE LENGTH (FT.)													
Natural Gas at 1000 B.T.U. per Cubic Ft.													
Propane Gas at 2500 B.T.U. per Cubic Ft.													
Model #	BTUs	3/4"		1"		1-1/4"		1-1/2"		2"		2-1/2"	
		NG	PRO	NG	PRO	NG	PRO	NG	PRO	NG	PRO	NG	PRO
220	110,000	50'	80'	125'	250'	450'	600'	-	-	-	-	-	-

Table 1: Gas Pipe Sizing

Checking Gas Pressure Through Gas Control Valve

WARNING Risk of explosion if a unit burning propane gas is installed in a pit or other low spot. Propane is heavier than air. Do not install the heater using propane in pits or other locations where gas might collect. Consult your local building code officials to determine installation requirements and specific installation restrictions of the heater relative to propane storage tanks and filling equipment. Installation must meet the requirements for the Standard for the Storage and Handling of Liquefied Petroleum Gases, CAN/CSA B149.2 (latest edition) or ANSI/NFPA 58 (latest edition). Consult local codes and fire protection authorities about specific installation restrictions.

The UltraTemp ETi™ Hybrid Heater is 100% factory tested, however Pentair recommends installations be tested to ensure proper combustion and optimal performance. During the initial startup, run the heater continuously for at least 10 minutes and then insert a probe connected to a combustion analyzer capable of reading CO and either CO₂ or O₂ into the exhaust vent. Wait for the reading to stabilize and confirm values are consistent with ranges in **Table 2**. If combustion values are outside of these ranges, contact technical support.

Measured Gas	High	Low
CO	150	-
CO ₂	9.2	7.8
O ₂	7.2	4.8
Air-Free CO	199	-

Table 2

This appliance is equipped with an unconventional gas control valve that is factory set with a manifold pressure of $-0.2''$ (-0.5cm) wc. Installation or service must be performed by a qualified installer, service agency, or the gas supplier. If this control valve is replaced, it must be replaced with an identical control.

The combination gas valve incorporates dual shut-off valves and a negative-pressure regulator. For proper operation, the regulated pressure at the outlet manifold of the valve must be $-0.2''$ (-0.5cm) wc below the reference pressure at the blower mixer inlet, and the gas valve 'VENT' tap must be connected to the end cap air orifice as shown in **Figure 16**.

Do not attempt to adjust the gas input by adjusting the regulator setting. The correct gas regulator setting is required to maintain proper combustion and must NOT be altered.

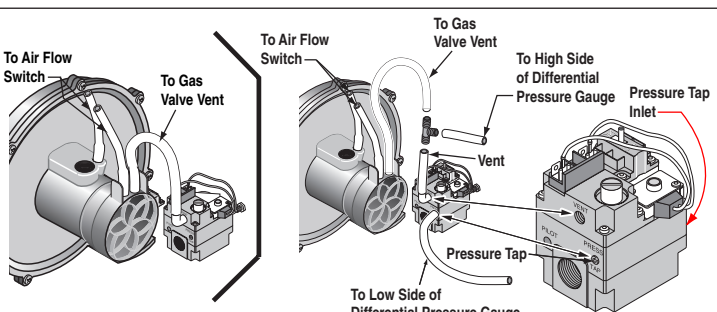

Figure 16

Sediment Traps

Install a sediment trap and union located outside the heater panels in accordance with National code requirements. Do not use a restrictive gas cock. The sediment trap shall be either a tee fitting with a capped nipple in the bottom outlet which can be removed for cleaning, as shown in **Figure 17**, or an other device recognized as an effective sediment trap. All gas piping should be tested after installation in accordance with local codes.

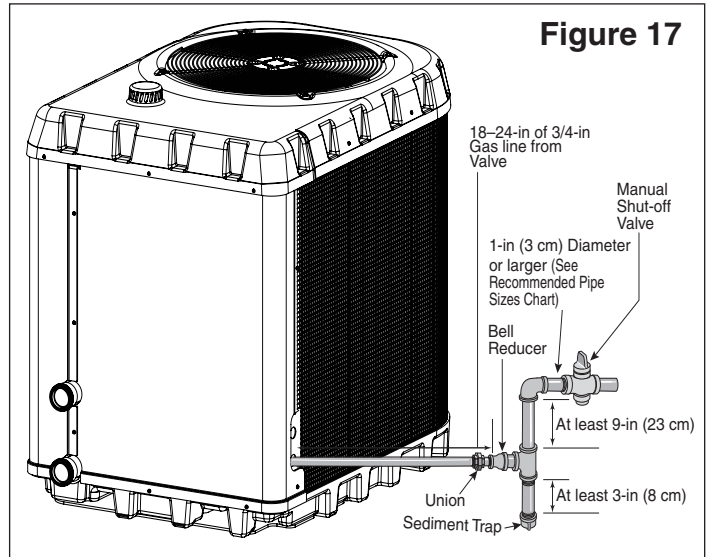

Figure 17

Gas Pressure Testing

CAUTION The heater and its manual shut-off valve must be disconnected from the gas supply during any pressure testing of that system at test pressures in excess of 1/2 psi (3.45 Kpa). Dissipate test pressure in the gas supply line before reconnecting the heater and its manual shut off valve to gas supply line. Failure to follow this procedure may damage the gas valve. Over pressurized gas valves are not covered by warranty. The heater and its gas connections shall be leak tested before placing the appliance in operation.

Before operating the heater, the heater and its gas connections must be leak tested. Do NOT use an open flame to test for leaks. Test all gas connections for leaks with soapy water or another non-flammable method.

The heater and its individual shut-off valve must be disconnected from the gas supply piping system during any pressure testing of that system at test pressures in excess of 1/2 psig (3.5 kPa). The heater must be isolated from the gas supply system by closing its individual manual shut-off valve during any pressure testing of the gas supply at test pressures equal to or less than 1/2 psig (3.5 kPa).

Note: Do not use threaded seal tape on gas line pipe thread. A pipe compound rated for use with natural and propane gases is recommended. Apply sparingly only on male pipe ends, leaving the two end threads bare.

Electrical Connections and Wiring

⚠ WARNING

RISK OF ELECTRICAL SHOCK OR ELECTROCUTION.

This heater contains wiring that carries high voltage. Contact with these wires could result in death or serious injury to pool or spa users, installers, or others due to electrical shock, and may also cause damage to property. Always disconnect power circuit before connecting the heater.



⚠ CAUTION

Label all wires prior to disconnection when servicing controls. Wiring errors can cause improper and dangerous operation. Verify proper operation after servicing.

⚠ CAUTION

If, while there is line voltage connected to the heater, you touch either line voltage terminal with any 24VAC wire that is connected to the control board, you will immediately destroy the control board and void the warranty.

General Information

Wiring connections must be made exactly as shown in the wiring diagrams on pages 14-15.

The UltraTemp ETi™ Hybrid Heater includes a definite means of grounding and bonding. There is a ground lug inside the heater electrical compartment and a bonding lug on the lower right side, adjacent to the service connections.

Enclose the incoming AC power line to the heater in an approved flexible conduit connected directly to the service port. Run wiring inside the heater into the main electrical compartment on the inside of the upper right side of the heater. Refer to page 35, “*Electrical Supply Voltage Requirements*” to verify field wiring requirements.

Bonding

The National Electrical Code and most other codes require that all metallic components of a pool structure, including reinforcing steel, metal fittings, and above ground equipment be bonded together with a solid copper conductor not smaller than 8 AWG. For Canada, a 6 AWG or larger solid copper bonding conductor is required. The heater, along with pumps and other pool equipment must be connected to this bonding grid.

A bonding lug is provided on the lower right side of the heater base, by the electrical and gas connections. See **Figure 18**.

⚠ CAUTION

This heater must be connected to a bonding grid with a solid copper wire not smaller in diameter than 8 ga. For Canadian installations a solid copper wire not smaller in diameter than 6 ga should be used.

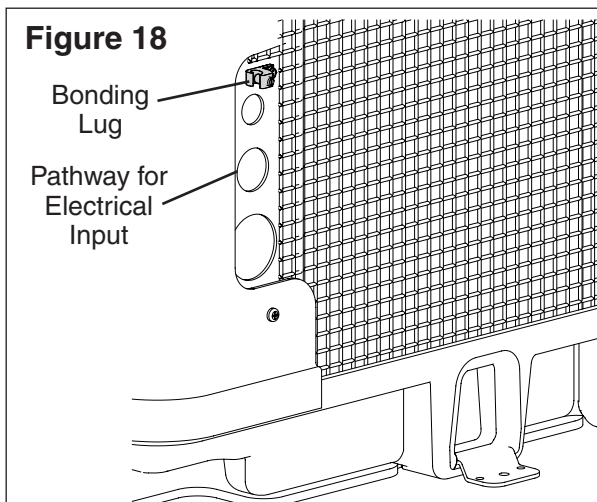

Main Power

Electrical wiring to the heater must be in accordance with the latest edition of the National Electric Code (NEC), ANSI/National Fire Protection Association (NFPA) 70 in the United States, and in Canada, the Canadian Electrical Code (CEC) C22.1, unless local code requirements indicate otherwise. All wiring must be done by a certified or qualified electrician.

The following is the procedure to wire the heater to the electrical source:

Be sure the power to the circuit for the heater is turned off.

1. Remove the long side service panel of the heater cabinet. There is no need to remove the star-head screws.
2. Remove the short side service panel to the heater electrical compartment.
3. Remove the sheet metal cover from the main electrical compartment.
4. Electrical supply lines must be run through watertight conduit. Run the wires and conduit from the power source and connect them to the conduit connection on the right side of the heater. See **Figure 18**.
5. Connect the power leads to the bottom terminals on the main compressor contactor as shown in the wiring diagram. See page 15.
6. Verify that all other contactor wires are secure, they may have loosened during shipment.
7. Connect the ground wire to the ground lug provided on the bottom of the electrical compartment.
8. Replace the sheet metal cover over the main electrical compartment.
9. Replace the short side service panel and reinstall screws to hold it in place.
10. Replace the long side service panel.
11. Connect a copper bonding wire (8 AWG) (6 AWG in Canada) to the bonding lug on the side of the heater.

Wiring Diagram - Input Side

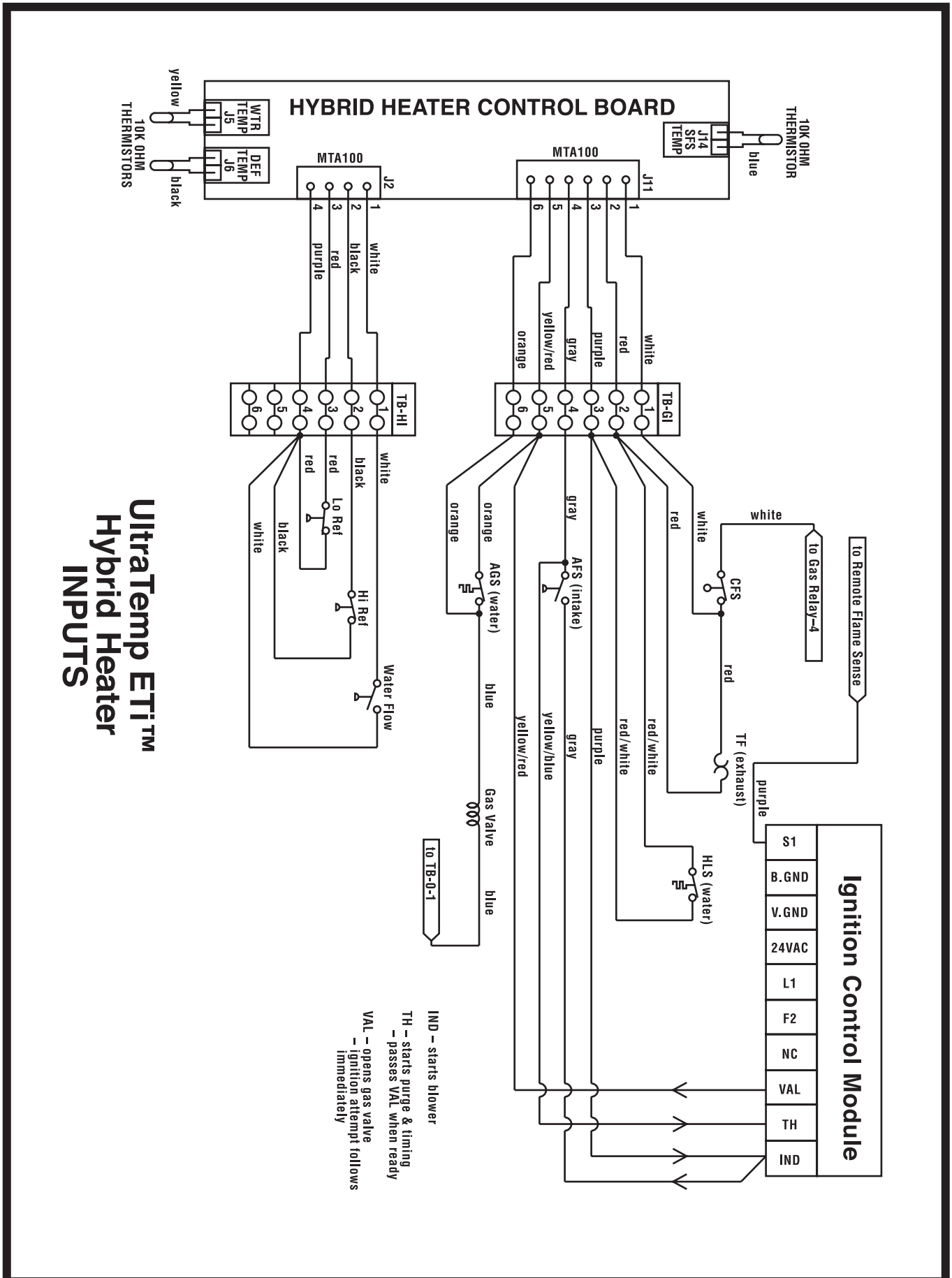

Wiring Diagram - Output Side

UltraTemp ETi™
Hybrid Heater
OUTPUTS

For field-wired connections
use #8 AWG or larger wires
rated for at least 170°F (75°C).

P/N 476088.B 4/10/18

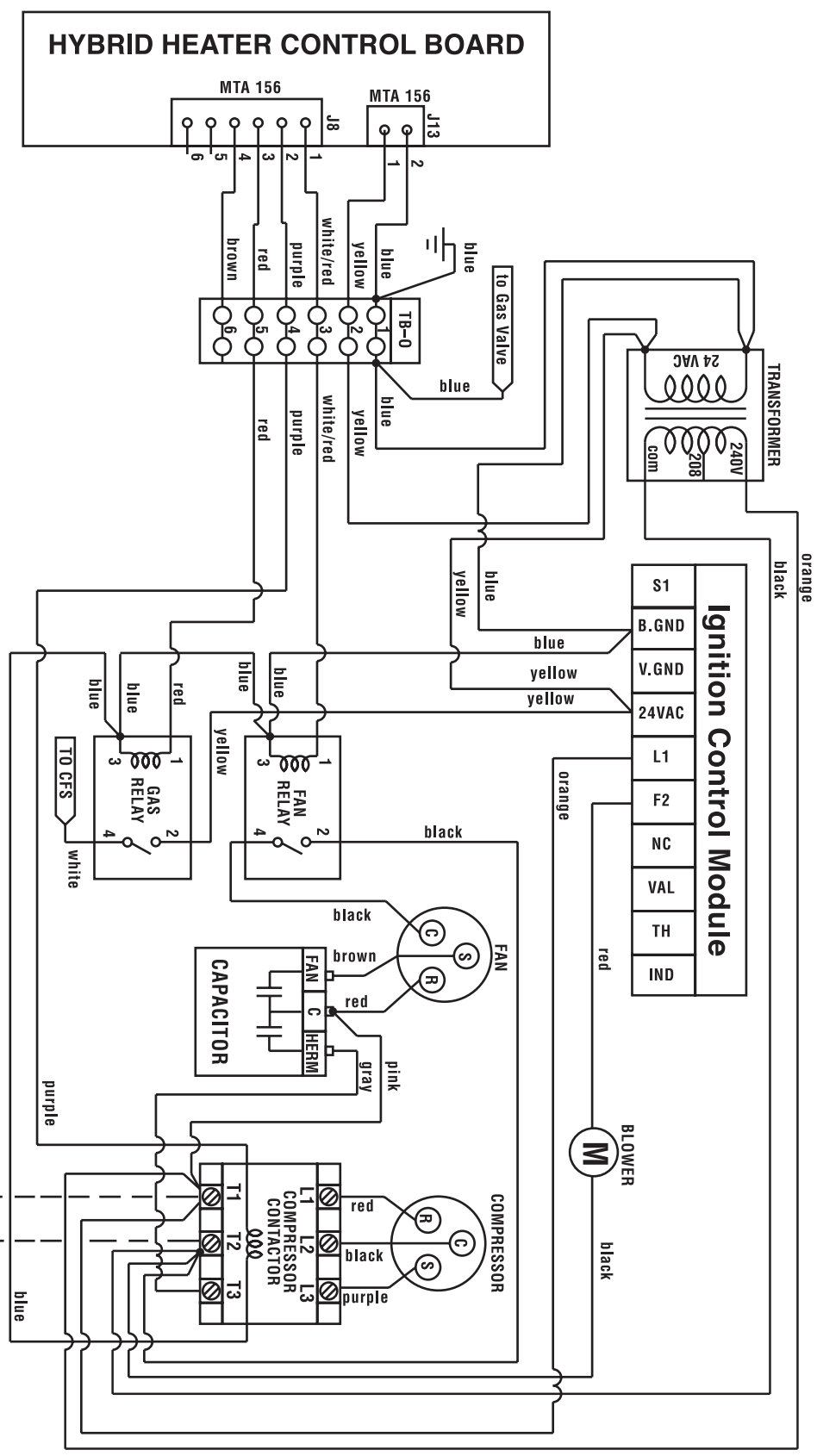

CONNECTING TO AN AUTOMATION SYSTEM

Remote Operation

The UltraTemp ETi™ Hybrid Heater may be connected to an automation system via the remote spade terminals on the back of the control board (see page 17) or via the RS-485 communication connector on the back of the control board (see page 18). Refer to the EasyTouch® Control System Installation and User's Guide for more information.

Remote connection via the RS-485 connector is only available on EasyTouch software version 2.169 or later. All other automation packages must connect via the ¼ in. "Spade" terminals (spade connector not supplied).

Relay Remote Controls

Electrical wiring must be in accordance with the latest edition of the NEC (NFPA 70) in the United States and CEC (CSA 22.1) in Canada, unless local code requirements indicate otherwise.

To connect remote control equipment to the heater, perform the following steps:

1. Turn off the power to both the remote pool/spa control system and the heater.
2. Remove the side panel of the heater cabinet, (you do not need to remove the star-head screw at the top left corner).
3. Remove the four (4) bezel retaining screws from above the bezel and rotate the bezel downward. This will allow you to access the Remote terminals on the back of the heater control board for the remote control installation.
4. Run the wires from the pool/spa remote control system into the upper electrical compartment.
5. Connect the wiring from the pool/spa remote control system to the heater remote control terminals using ¼ in. (6.4 mm) "Spade" connectors as shown in the image below.
6. Rotate the bezel back into position and reinstall the four (4) retaining screws.
7. Replace the side panel.
8. Restore power to the heater and the pool/spa remote control system.
9. Press the MENU SELECT button repeatedly to scroll to the Remote Mode screen. Toggle the selection by pressing one of the arrows until the screen displays "Relay".
10. Turn on the heater.

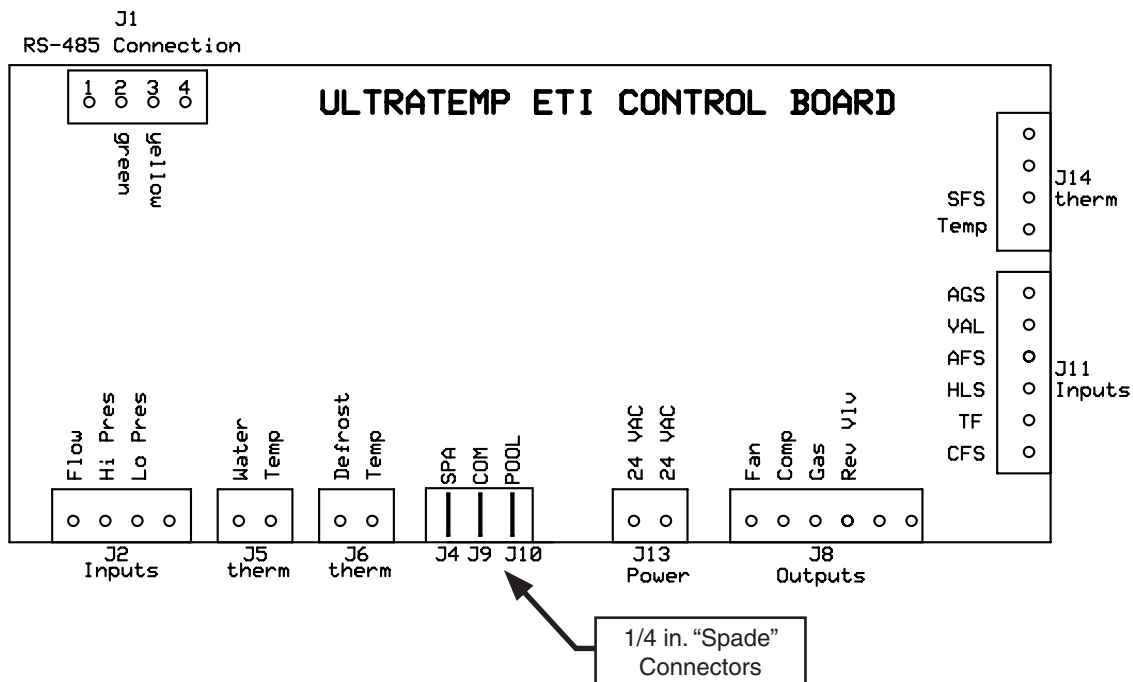

Connecting the Heater to the EasyTouch® Control System Load Center via the Heater Spade Terminals

To connect the UltraTemp ETi™ Hybrid Heater cable to the Personality Board in the EasyTouch Load Center:

1. Turn off the main system power before making any connections.
2. Unlatch the front door spring latches, and open the front door of the EasyTouch Load Center.
3. Loosen the two retaining screws from the top of the control panel and lower the control panel down to access the Personality Board.
4. Run a UL approved conductor cable from the heater to the Load Center.
5. Route the cable up through the low voltage raceway located on the left of the Load Center to the Personality Board, see image below.
6. Insert the UltraTemp ETi cable into the gas heater terminal connector, located on the Personality Board.
7. Lift the control panel up into position and secure with the two screws.
8. Connect the cable from the EasyTouch Load Center to the heater remote control terminals using ¼ in. (6.4 mm) "Spade" connectors, Refer to previous page for wiring instructions.

Note: Solar temperature sensor could be left loose in load center. The automation system does not use the temperature reading but just looks for resistance.

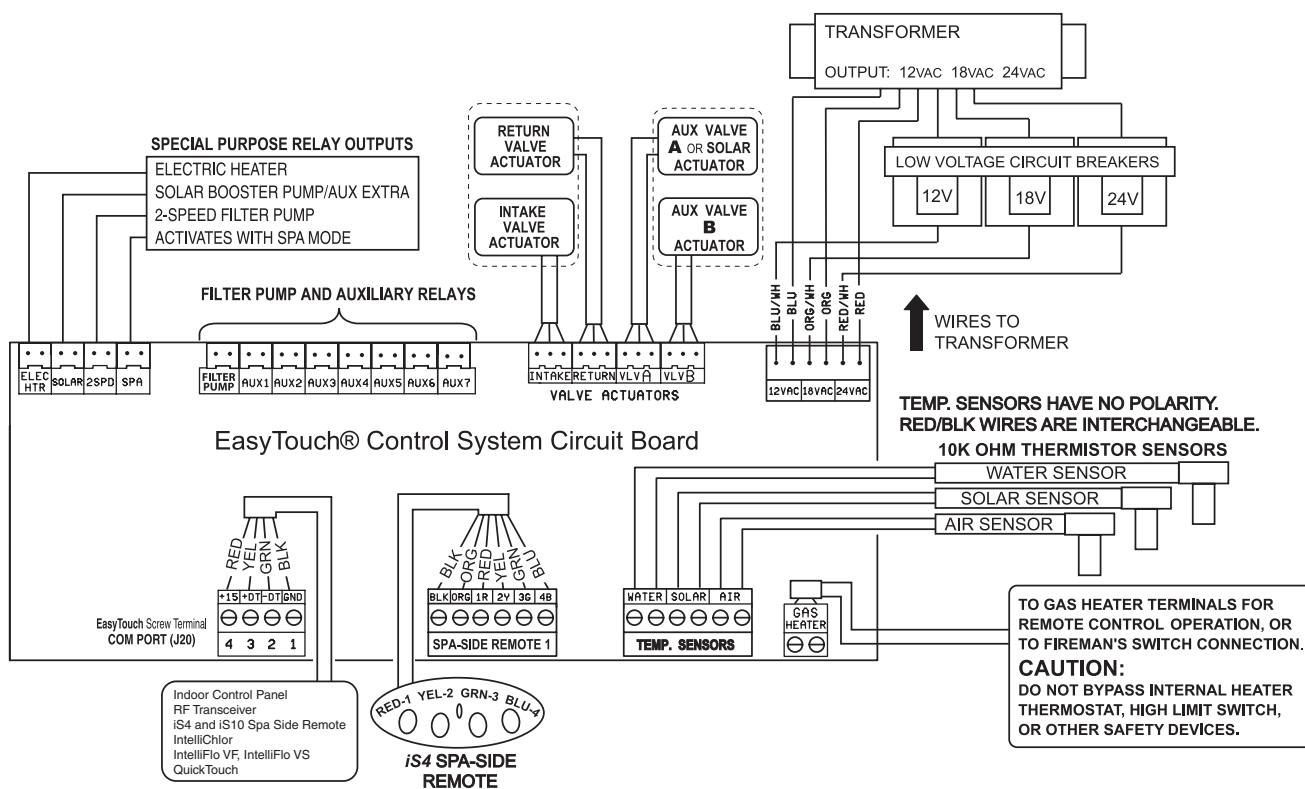

EasyTouch Load Center Wiring Diagram

Connecting the Heater to the EasyTouch® Control System Load Center via the RS-485 Connector



Switch the main power off to the EasyTouch load center before servicing.

The UltraTemp ETi™ Hybrid Heater can be controlled by an EasyTouch system via the RS-485 communication cable.

The transfer of this data takes several seconds and causes a delay from when the command is given from the EasyTouch indoor control panel until the heater physically responds. This happens automatically but may take 1-2 minutes to complete.

Note: Heater control board set points will be shown as “N/A” and will be functionally disabled. For more information, refer to the EasyTouch User’s Guide (P/N 520584) or the EasyTouch Wireless System User’s Guide (P/N 520688).

Connection from heater board to the EasyTouch system is via the optional four-wire cable (P/N 520199).

To connect the heater board cable to the EasyTouch load center:

1. Turn off the main system power before making any connections.
2. Unlatch the EasyTouch load center front door spring latches, and open the front door.
3. Remove the cover-panel screws securing the high voltage cover-panel, and remove it from the enclosure.
4. Loosen the two control panel access screws and fold down the outdoor control panel.
5. Insert the four-wire cable into plastic grommet on the bottom of the enclosure and route the wire up through the low voltage raceway to the Personality board.
6. Strip back the cable conductors ¼-in (6.4 mm). Insert the wires into the J20 COM PORT screw terminals located on the left side of the Personality board. Secure the wires with the screws. For wiring details, refer to the pin configuration as shown on page 19.

Note: Multiple wires may be inserted into single screw terminal.

7. Close the control panel and secure it with the two access screws.
8. Install the high voltage panel cover and secure it with the two retaining screws.
9. Close the load center front door and secure with the two latches.
10. Switch power on to the load center.

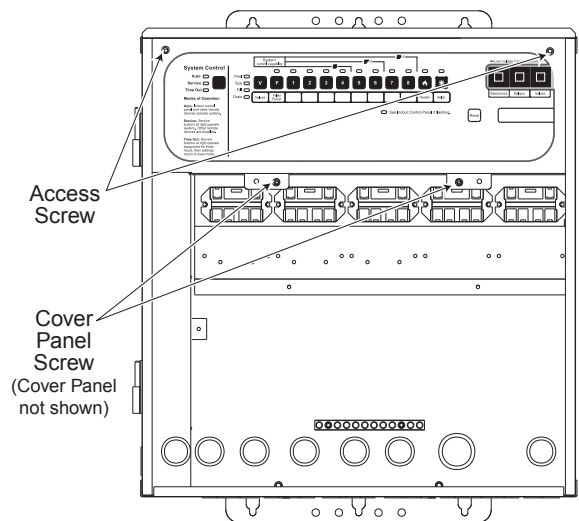
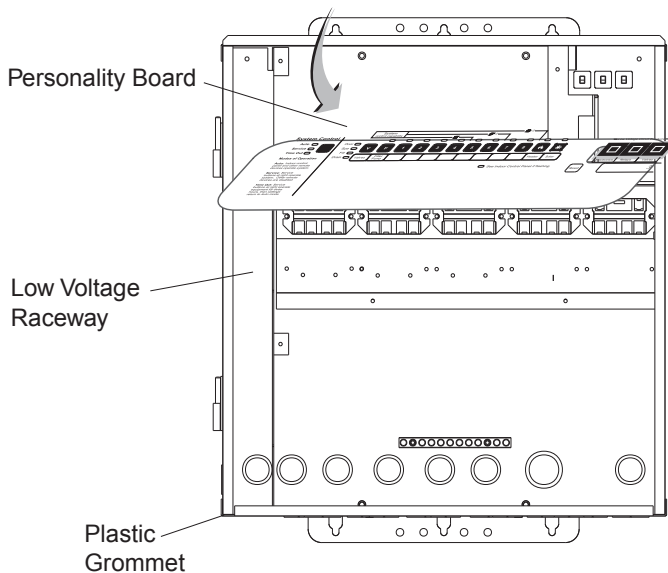

Automation Load Center

Pin Configuration for the Heater Control Board to EasyTouch® Control System

1. Heater Control Board: Connect pin 2 (green) to EasyTouch screw terminal pin 2 (green).
2. Heater Control Board: Connect pin 3 (yellow) to EasyTouch screw terminal pin 3 (yellow)

IMPORTANT — Do **NOT** use pin 1 (black) or pin 4 (red) on the EasyTouch personality board.

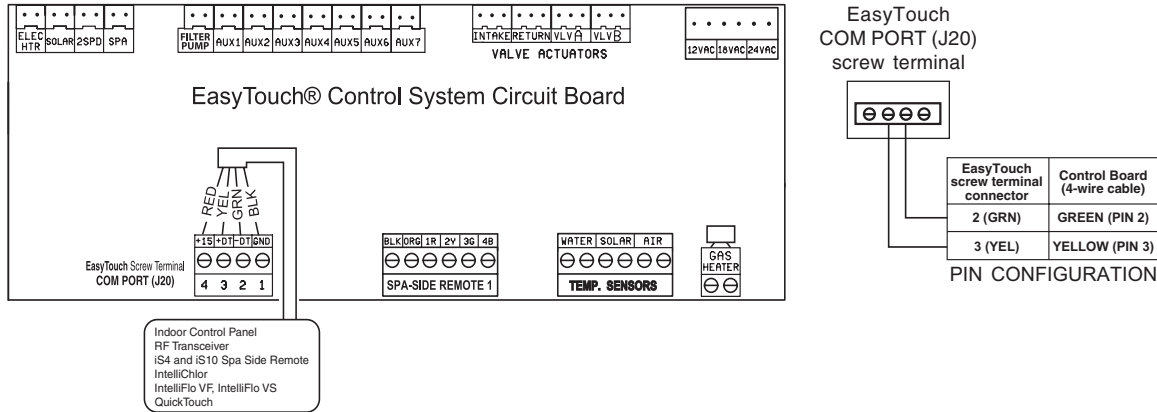

Connecting the EasyTouch to Heater

1. Turn off the power to both the remote pool/spa control system and the UltraTemp ETi™ Hybrid Heater.
2. Remove the side panel of the heater cabinet, (you do not need to remove the star-head screw at the top left corner).
3. Remove the four (4) bezel retaining screws from above the bezel and rotate the bezel downward. This will allow you to access the Remote terminals on the back of the heater control board for the remote control installation.
4. Run the wires from the pool/spa remote control system into the low voltage box.
5. Connect the wiring from the EasyTouch Personality Board COM PORT to the RS-485 connection (J1) on the heater control Board. Connect the green wire to J1 pin 2 and yellow wire to J1 pin 3. Do NOT use pin 1 (red) or pin 4 (black) wires. The connections are shown in the image on page 16.
6. Rotate the bezel back into position and reinstall the four (4) retaining screws.
7. Replace the side panel.
8. Restore power to the heater and the EasyTouch control system.
9. Press the MENU SELECT button to scroll to the Remote Mode screen. Toggle the selection by pressing one of the arrows until the screen displays “RS-485.”
10. Once the heater has been correctly configured, a “heartbeat” indicator will appear on the main screen each time a message is received from the automation system.

HYBRID F ★ [] - - - Heartbeat Indicator
SET= N/A ACT= 74

Note: If the system is put into Service Mode at the automation control panel the heater will not heat, although it will remain powered on.

OPERATING THE HEATER



WARNING Risk of explosion or fire causing burns or death if safety interlocks are disabled. **DO NOT** attempt to operate heater when SERVICE HEATER light is on or if blower or burner will not start. Instead, follow instructions under “To Switch Off Gas to the Appliance,” and call a qualified service technician to repair unit.



WARNING If you do not follow these instructions exactly, a fire or explosion may result causing property damage, personal injury or loss of life. Do not attempt to light the heater if you suspect a gas leak. Lighting the heater can result in a fire or explosion which can cause personal injury, death, and property damage.



CAUTION Do not use this heater if any part has been under water. Immediately call a qualified service technician to inspect the heater and replace any part of the control system which has been under water. Keep all objects off the top of the heater. Blocking air flow could damage the unit and may void the warranty.

ATTENTION - INITIAL START UP PRECAUTIONS

After the water pressure switch is activated there is a one minute temperature sensing delay then if there is a call for heat the fan will turn on and there may be an additional 5 minute delay for the compressor to start. Be sure that there is water in the pool and that the surface level is above the skimmer or other inlets of the pool's filter system.

The pool pump must be on and water flowing through the heater for it to operate.

With any new pool or spa installation, operate the filter pump with the heater off long enough to completely clean the water. This will remove any installation residue from the water. Clean the filter at the end of this operation before starting the heater. When raising the temperature of a cold pool, program the time clock to run the pump continuously. This lets the filter system and heater operate continuously until the water reaches the temperature setting on the temperature control. When that happens, the heater will automatically shut off, but the filter pump will keep running.

Swimming Pool Energy Saving Tips

For extended non-use, turn the heater completely off or decrease the temperature setting of the control several degrees to minimize energy consumption.

Pentair offers the following recommendations to help conserve energy and minimize the cost of operating your heater without sacrificing performance.

1. The American Red Cross recommends a maximum water temperature of 83-86°F [28.3-30°C]. Use an accurate pool thermometer. A difference of 3°F [1.7°C], between 83°F and 86°F [28.3°C and 30°C], will significantly increase energy consumption.
2. For pools used only on weekends, lower the thermostat setting by 10°F to 15°F (5°C to 8°C) during the week to reduce heat loss. A properly sized heater will restore normal temperature within one day.
3. Carefully monitor the water temperature of your pool in the summertime. You can reduce heater usage due to warmer air temperatures.
4. Use a time clock to start the filter pump at 6 a.m. or later. The swimming pool loses less heat after daybreak.
5. Find the proper setting on the heater temperature control and use the Keypad Lock function to discourage further adjustments.
6. Where possible, shelter the pool from prevailing winds with well-trimmed hedges or other landscaping, cabanas, or fencing.
7. Pentair recommends the use of a pool cover. Besides providing a valuable safety feature, a pool cover will reduce heat loss, conserve chemicals, and reduce the load on filter systems.
8. Perform regular preventive maintenance and inspections of the heater each new swimming season. This will prevent loss of heating efficiency over time.

Control Panel Overview

1. **ON/OFF** button – Turns the heater ON and OFF.
2. **MENU SELECT** button – Displays Operator Menu Screens; also used to scroll through these menus.
3. **MODE** button – Cycles through the available modes of operations; Heat Pump only, Gas only, Dual and Hybrid.
4. **UP and DOWN Arrow** buttons – The UP and DOWN arrows will raise or lower the temperature set point if pressed while the run screen is displayed. They are also used to scroll through the various parameter values on the Operator Menus and Service Menu screens.
5. **LCD SCREEN** – Displays operating mode, water temperature, setpoint temperature and heater parameters.
6. **ON Light** – Shows the heater is on.
7. **SERVICE Light** – Lit if alarm condition exists.

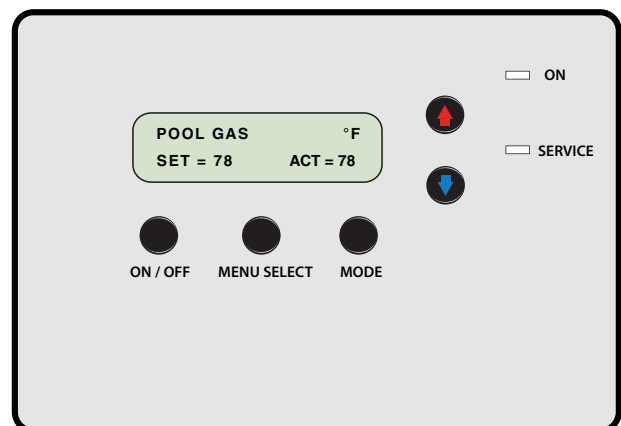

Sequence of Operation

An electronic temperature sensing gas-fired heater thermistor in the inlet plumbing controls the heater operation. When the inlet water temperature drops below the temperature set on the operator control panel, the control board supplies power to the combustion air blower through a series of safety interlocks.

The heater interlocks consist of:

- **Water Pressure Switch (WPS):** Senses that the pump is running.
- **Automatic Gas Shut-off (AGS) Switch:** Opens if the heat exchanger outlet temperature goes above 140° F (60° C).
- **High Limit Switch (HLS):** Opens if the heat exchanger outlet temperature goes above 127° F (53° C).
- **Air Flow Switch (AFS):** Senses the pressure drop across the air metering orifices.
- **Float Switch (CFS):** Opens if the condensate overflows at the float switch due to blockage in the condensate drain hose or neutralizer cartridge.
- **Stack Flue Sensor (SFS):** Monitors flue gas temperature and shuts down the heater if the gas temperature reaches 185° F (85° C).
- **Thermal Fuse (TF):** Opens if the flue gas temperature reaches 215° F (102° C).

The air flow switch (AFS) senses the pressure differential across the air metering orifice. As soon as there is sufficient air flow, the AFS closes, completing the circuit to the Direct Spark Ignition (DSI). The gas ignition control then opens the gas valve and the fuel mixture is ignited by the DSI. On a call for heat, the blower is energized for 15 seconds, the gas valve opens simultaneously as the direct spark igniters are energized, then ignition occurs. The heater is equipped with a digital operating control that enables the user to pre-set the desired pool and spa water temperatures. The control enables the user to select between pool and spa heating, and features a digital display that indicates the water temperature.

See page 25 for more details and explanations regarding heater features and programming.

Pre-Startup

1. This appliance does not have a pilot. It is equipped with an ignition device which automatically lights the burner. **DO NOT** try to light the burner by hand.
2. **BEFORE OPERATING**, smell all around the appliance area for gas. Be sure to smell next to the floor because some gas is heavier than air and will settle on the floor.

WHAT TO DO IF YOU SMELL GAS

- **DO NOT** try to light any appliance.
- **DO NOT** touch any electrical switch; do not use any phone in your building.
- Immediately call your gas supplier from a neighbor's phone. Follow the gas supplier's instructions.
- If you cannot reach your gas supplier, call the Fire Department.

3. Use only your hand to turn the gas control on or off. Never use tools. If you cannot change the ON/OFF setting by hand, don't try to repair it, call a qualified service technician. Forced or attempted repair may result in a fire or explosion.
4. Do not use this heater if any part has been under water. Immediately call a qualified service technician to inspect the heater and to replace any part of the control system and any gas control which has been under water.
5. Do not operate the pool heater unless the pool or spa is properly filled with water.
6. Before operating the appliance for the first time or after it has been off for an extended time, perform the following checklist:
 - a. Remove debris or other articles from inside the heater and the area around the heater and its exhaust vent. Make sure all openings for ventilation and combustion are clear of debris or obstruction.
 - b. Keep heater area clear and free from combustibles, flammable liquids and chemicals.
 - c. Check that all water connections are tight.
 - d. Water must be flowing through the heater during operation. Make sure that pool/spa is filled with water and have pump operating. Check that water flow is unobstructed from the appliance. When operating for the first time or after an extended shut-down, run filter pump for several minutes to clear all air from the system.

Basic Operating Instructions

1. STOP! Read the safety information on (page 20).
2. Turn off all electric power to the appliance.
3. This appliance does not have a pilot. It is equipped with an ignition device which automatically lights the burner. Do not try to light the burner by hand.
4. Remove the access panels by removing the Phillips head screws on each panel, then sliding the panels down and out.
5. Locate the toggle-style valve and pull the toggle toward you to turn gas off, see **Figure 19**.

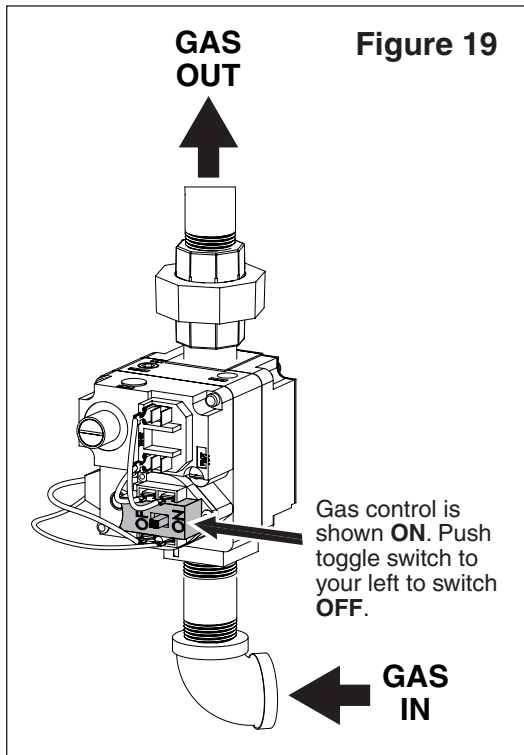

6. Wait five (5) minutes to clear out any gas. If you then smell gas, STOP! Follow directions given in *WHAT TO DO IF YOU SMELL GAS* at the top of the previous page. If you don't smell gas, go to the next step.
7. Push the toggle switch away from you to switch the gas on.
8. Replace the service panels. All panels must be in place when operating the heater.
9. Set 3-way valves on inlet and outlet to pool or spa, as appropriate.
10. Turn on all electric power to the appliance.
11. Ensure the pump is running.
12. Press ON/OFF button on the operating control.
13. Select operation mode.

14. Set the thermostat to desired setting.
Note: Setpoint must be above actual water temperature or burner will not fire.
15. The blower should come on immediately, and after about 15 seconds, the burner should fire. When operating for the first time, the burner may not fire on the first try because of air in the gas line. If it does not fire at first, push the ON/OFF button, wait five minutes, and again push the ON/OFF button. The burner should fire after about 15 seconds. You may have to repeat this until all of the air has cleared the gas line.
16. The burner should fire until the pool/spa temperature reaches the desired temperature set on the thermostat. The blower will continue to run for about 60 seconds after the burner shuts off. If any of the safety interlocks should open during burner operation, the burner shuts off immediately, but the blower continues to run for about 60 seconds. Should overheating occur or the gas supply fail to shut off, turn off the manual gas control valve to the appliance.
17. If the appliance will not operate, follow the instructions *Turning Off Gas to the Heater* below, and call your service technician or gas supplier.
18. If the electrical power is shut off to the heater while it is running, once power is restored, the heater will power up with the previous programmed settings.

Turning Off Gas to the Heater

1. Press the ON/OFF button on operating control.
2. Switch off all electric power to the unit.
3. Remove the service panels.
4. Toggle-Style Valve: Pull toggle toward you to turn gas off, see **Figure 19**.
5. Replace the service panels.

Safety Controls

Air Flow Switch (AFS)

There is an air flow switch (see **Figure 20**), designed as a safety device to ensure the combustion air blower (fan) is operating and monitoring the differential (negative) pressure within the blower housing. The air pressure switch is factory set. The switch is connected upstream of the ignition module. The ignition module does not operate unless the air flow switch and all safety switches are closed.

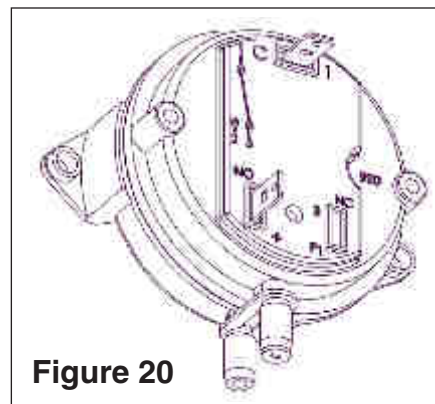

Figure 20

Water Pressure Switch (WPS)

WARNING Hazardous pressure. Do not bypass the Water Pressure Switch or render it inoperable.

The heater has a Water Pressure switch, see **Figure 22**. If the water flow is restricted, the water pressure switch may prevent the burner from firing and cause the Service System LED indicator to go on.

Note: If the light remains on after the filter has been serviced, have a qualified service technician check the system.

For proper adjustment of the water pressure switch, refer back to page 10, *Water Pressure Switch Adjustment*. Turn the star-wheel on the switch clockwise (↻) to raise setting (heater below the pool level) and counterclockwise (↺) to lower the setting (heater above the pool level), see **Figure 21**. Test the switch after resetting.

WARNING Heater operation with an incorrect water pressure switch setting, may cause the heater to operate without sufficient water flow, and may cause severe heater damage.

Turn star wheel **clockwise** to raise pressure set point

Figure 21

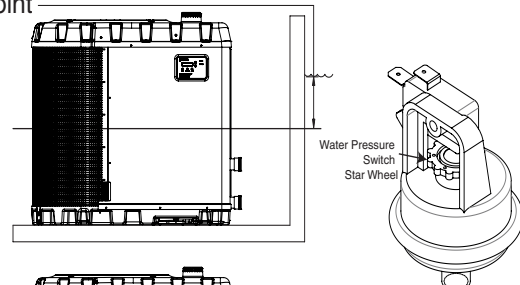

A reference scale is on the back of pressure switch

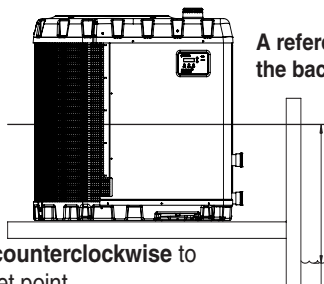

Turn star wheel **counterclockwise** to lower pressure set point

High Limit Switch (HLS) and Automatic Gas Shut-off Switch (AGS)

A High Limit Switch (HLS), is a thermostat that opens the electrical circuit and shuts off the heater based on a water temperature set point within the HLS. Both the AGS and HLS switches located in the outlet plumbing assembly (see **Figure 22**).

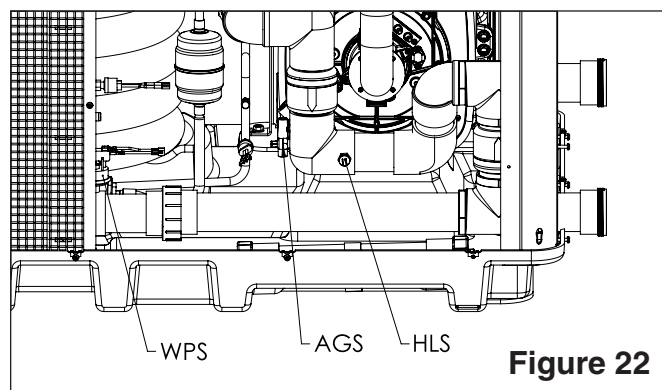

Figure 22

Stack Flue Sensor (SFS)

The heater is equipped with a Stack Flue sensor. This sensor monitors the stack flue temperature and if needed will shut down the heater if the stack flue temperature exceeds 185° F (85° C).

Thermal Fuse (TF)

A Thermal Fuse (TF) is a safety protection device that opens the electrical circuit if the exhaust gas temperature reaches 215° F (102° C). The fuse cannot be reset, it must be replaced.

Float Switch (CFS)

The Float Switch (CFS) is a sensing application that shuts down the heater once the condensate level exceeds the permitted level in the condensate container.

Ignition Module Operation

The Ignition Module, (**Figure 23**), is microprocessor based and operates on 24VAC supplied by the transformer. The module utilizes a microprocessor to continuously monitor, analyze, and control the proper operation of the gas flame holder. The module with the presence of the flame sensor, using flame rectification, allows the heater to operate.

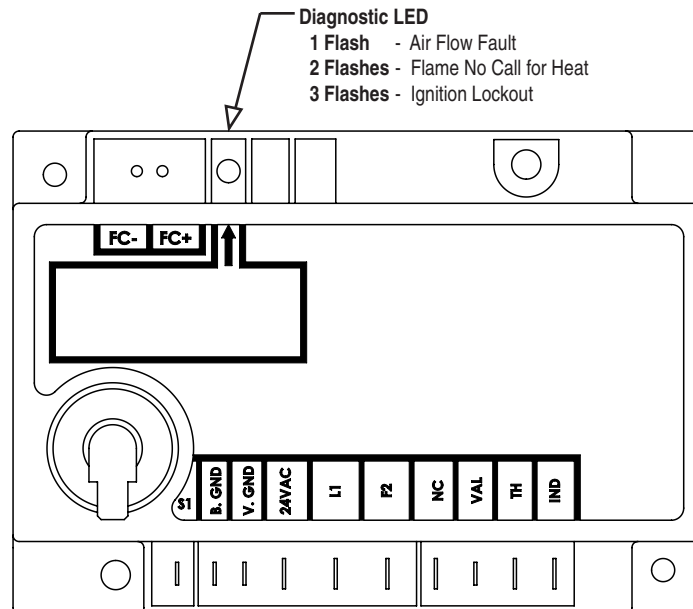
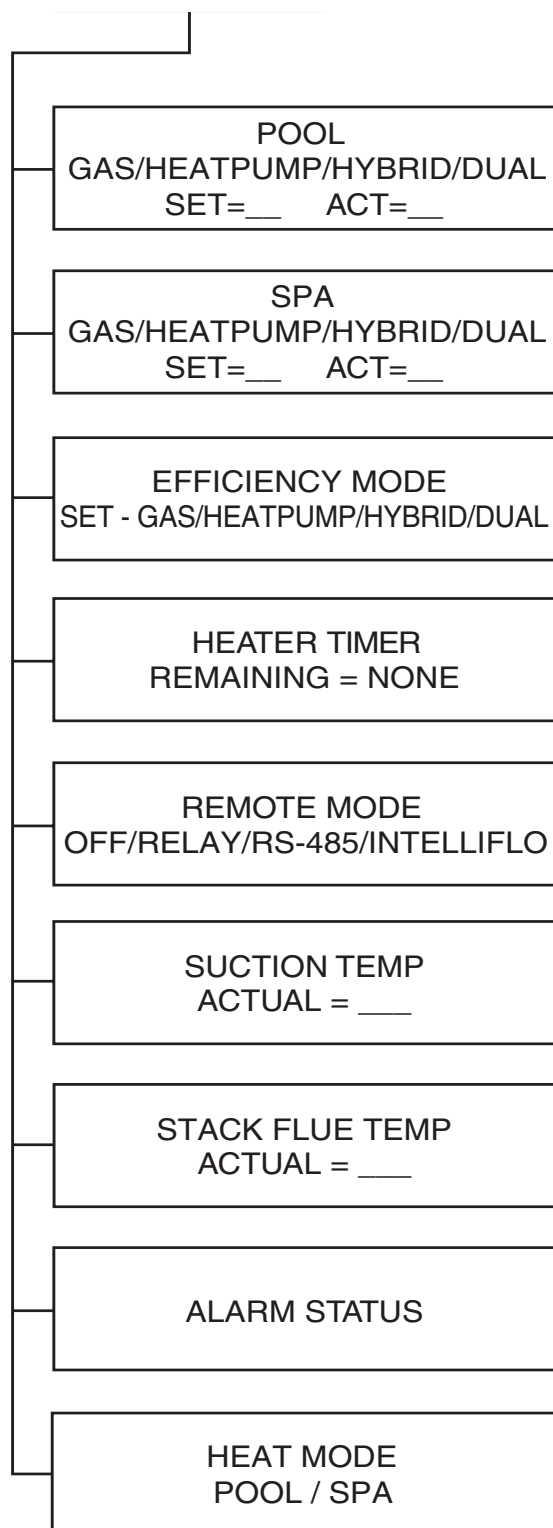

Figure 23: Ignition Control Module

Operator Menu Tree Guide

(Press Menu Select Button)



Navigating the Operator Menu Screens

Press the MENU SELECT button to view each screen. While in the menu screens, if no activity is detected after 15 seconds, the main screen is displayed.

Pool and Spa Set Point Screens

Displays the pool or spa water temperature set point and the actual measured water temperature. This screen allows the operator to set the pool or spa set points.

Efficiency Mode Selection Screen

This screen allows the operator to switch the heater between Gas only, Heat Pump only, Hybrid or Dual operating modes.

Heater Timer Screen

This feature is an adjustable timer to allow the heater to run (green light ON) for a predetermined amount of time and then turn OFF (green light OFF).

Remote Mode Screen

Allows the operator to select the Remote mode, Off, Relay, RS-485 (serial) or IntelliFlo. In RS-485 Remote mode, the heater is controlled by an automation controller. In IntelliFlo Remote mode, the heater communicates with and activates an RS-485 connected IntelliFlo pump when the heater is attempting to heat to its set point.

Suction Temperature Screen

Shows the suction line temperature of the refrigerant. This screen only appears if the Defrost feature is enabled.

Stack Flue Temperature Screen

Shows the current stack flue temperature.

Alarm Status Screen

Shows if an alarm condition is present. If no alarms are present the screen will display ALARM STATUS NONE. The control board has the ability to store a 30 Alarm history of previous alarms that have occurred. At the alarm status screen, press the DOWN arrow. The first alarm will be the most recent alarm that has occurred. Successive presses (up to 30) of the DOWN arrow will display the alarm history in the order of occurrence. The operator can scroll back up using the UP button.

Heat Mode Screen

Displays whether the heater's pool or spa settings are active. The heat mode can be switched between Pool and Spa by using the UP and DOWN arrows.

Using the Operator Menus

Starting and Stopping the Heater

The UltraTemp ETi™ Hybrid Heater is started and stopped with the ON/OFF button.

1. Starting - With power supplied to the heater, press the ON/OFF button to start the heater. The ON light should be lit.
2. Stopping - Press the ON/OFF button to stop the heater; the ON light will turn off. The screen shown below will be displayed temporarily.

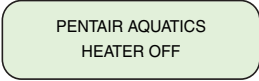

PENTAIR AQUATICS
HEATER OFF

Changing the Set Point (Temperature)

The control board has two independently adjustable temperature set points. One is for the pool temperature control and the other is for the spa temperature control. The active mode of operation (Pool or Spa) is defined as the “active” set point.

1. Press the MENU SELECT button repeatedly until the associated run screen is displayed. Press the UP or DOWN arrows to adjust the pool or spa temperature set point.
SET= ___ - Set point
ACT= ___ - Actual measured water temperature
2. The screen automatically returns to the active run screen after 15 seconds of keypad inactivity.

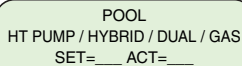

POOL
HT PUMP / HYBRID / DUAL / GAS
SET=___ ACT=___

Efficiency Mode Selection

These heaters can be setup to operate in any one of four modes (Heat Pump Only, Gas Only, Hybrid or Dual).

In Hybrid mode, the heater automatically switches between heating the water by means of heat pump or gas heating in order to maximize efficiency. In Dual mode the heat pump functionality and gas heater will work in tandem to heat the pool/spa.

1. Press the MENU SELECT button repeatedly until the Mode Selection screen displays.
2. Press the UP or DOWN arrows to scroll through the HEAT PUMP, GAS, HYBRID and DUAL options. The last option shown on the display becomes active.

Heater Timer

This feature is an adjustable timer to allow the heater to run for a predetermined amount of time (green light ON) and then turn OFF (green light OFF).

During the selected time frame, the green light is ON and the heater functions in the normal mode of operation. When time expires the green light turns OFF and the heater turns off. Countdown time is in hours and minutes.

To activate the Heater Timer:

1. Press MENU SELECT repeatedly until the Heater Timer screen is displayed.
2. Press UP or DOWN arrows to set the amount of time (range of 10 minutes to 99 hours). Timer adjusts in increments of 10 minutes.
If the heater is not already on, setting the timer will activate and start the heater.
3. The user can also change the time while it is active using the arrow buttons, but only if Remote mode is OFF. Setting Remote Mode to RELAY or RS-485 disables the Heater Timer at the control panel.
4. Any RS-485 communication received will reset the timer to zero. The RS-485 overrides the Heater Timer operation.
5. The timer can be disabled by pressing the DOWN arrow and MODE buttons at the same time, or by pressing the ON/OFF button.

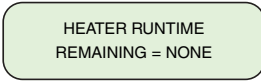

HEATER RUNTIME
REMAINING = NONE

Remote Mode - Relay

In Relay Remote Mode operation, the heater is started and stopped by remote relays which are connected to the remote POOL, COMMON and SPA quick connect terminals on the back of the control board.

When conductivity is provided between the POOL and COMMON terminals or the SPA and COMMON terminals, the heater will start. All other features and functions (except for the Heater Timer) are still active. The heater will not heat above 104°F (40°C).

To activate the Relay Remote Mode:

1. Press MENU SELECT repeatedly until the Remote Mode screen is displayed. Once displayed, press the UP or DOWN arrows to select RELAY. The last option shown on the display becomes active.

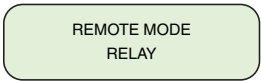

REMOTE MODE
RELAY

Remote Mode - RS-485 (Serial Cable)

See *EasyTouch® Control System Installation User's Guides* for additional setup instructions.

In RS-485 Remote mode, the heater is started and stopped via a serial RS-485 communications link with a Pentair automation controller. The high and low temperature faults are still active; the heater will not heat above 104°F (40°C).

Note: If the system is put into Service Mode at the automation control panel the heater will not heat the pool, although it will remain powered on.

To activate the RS-485 Remote mode:

1. Press MENU SELECT repeatedly until the Remote mode screen is displayed. Once displayed, press the UP or DOWN arrows to select RS-485.

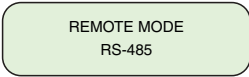

REMOTE MODE
RS-485

To use the RS-485 Remote mode, the Intell Address screen from the Service Menu Tree must be assigned to the proper address. One (1) is the most commonly used address.

The address on the Intell Address screen must match the address assigned to the heater. The heater address can be changed from the Service Menu as described below:

1. Press the UP and DOWN arrows simultaneously.
2. Then press the MENU SELECT button repeatedly until the Intell Address screen is displayed. Once displayed, press the UP or DOWN arrows to select the address being used in the automation controller. The last address shown on the display will become active.

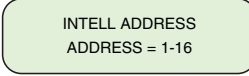

INTELL ADDRESS
ADDRESS = 1-16

3. Once the heater has been correctly configured, a "heartbeat" indicator will appear on the main screen each time a message is received from the automation system.

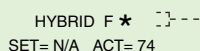

HYBRID F ★ [] --- Heartbeat
SET= N/A ACT= 74 Indicator

Remote Mode - IntelliFlo

In IntelliFlo Remote mode, the heater communicates with an RS-485 connected IntelliFlo or IntelliPro pump to ensure water is flowing through the heater when water heating is required.

Note: This feature requires that an RS-485 communication cable be connected between the heater control board and the IntelliFlo or IntelliPro pump drive.

When the water temperature falls below the heater's set point, a command is sent to the connected pump instructing the pump to run its External Control #4 speed.

When the water temperature reaches the programmed set point, a command is sent to the pump instructing it to stop running External Control #4 and return to its previous operating state.

To activate the IntelliFlo Remote Mode:

1. Press MENU SELECT repeatedly until the Remote Mode screen is displayed. Once displayed, press the UP or DOWN arrows to select INTELLIFLO.

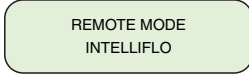

REMOTE MODE
INTELLIFLO

Timers And Delays

Water Sensing Timer

One (1) minute timer to allow water from the pool to reach the UltraTemp ETi™ Hybrid Heater before acquiring temperature. This timer initiates when water first begins to run from stopped or low water flow conditions or when the heater is turned ON. Countdown time is in Minutes and Seconds.

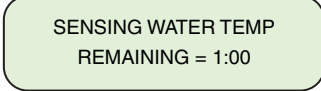

SENSING WATER TEMP
REMAINING = 1:00

Restart Delay Timer

Five (5) minute timer is a protection feature for the heater's compressor. This extends the life of the compressor by not allowing it to cycle on and off rapidly, (i.e. adjusting set point up and down around actual temperature). Countdown time is in minutes and seconds.

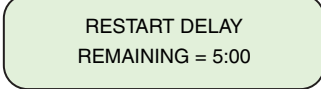

RESTART DELAY
REMAINING = 5:00

Heater Runtime Timer

This feature is an adjustable timer to allow the heater to run for a predetermined amount of time and then turn OFF. During the selected time frame the green light is ON and the heater will function in the normal mode of operation and/or the operator can change set points, functions, etc. The heater's green light will turn OFF and the heater will stay OFF when time expires.

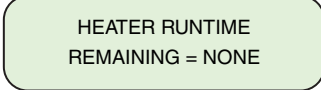

HEATER RUNTIME
REMAINING = NONE

Control Panel Alarm Messages

HIGH WATER TEMP	Water temperature is above 104° F [40° C].
LOW WATER TEMP	Water temperature is below 40° F [4.4° C].
LOW WATER FLOW	The pressure switch sensing water flow is open.
REMOTE POOL/SPA	Pool and Spa relay remote inputs are simultaneously energized.
WATER THERM SHORT	Water temperature thermistor circuit shorted.
WATER THERM OPEN	Water temperature thermistor circuit open.
SUCTION TH SHORT	Defrost thermistor circuit shorted
SUCTION TH OPEN	Defrost thermistor circuit open.
LOW AMBIENT TEMP	Air temperature is too low for heat pump operation
BROWNOUT	The 24 VAC supply voltage to the control board is low.
HIGH REFRIG	Refrigerant high pressure switch is open.
LOW REFRIG	Refrigerant low pressure switch is open.
SERIAL COMM FAULT	Control board has not received a reply message for two (2) minutes.
FIVE ALARMS	Indicates that five (5) faults have occurred in one (1) hour. This fault will automatically reset in one (1) hour or can be manually reset by pressing the ON/OFF button.

HI LIMIT SWITCH	Water temperature is above 127° F [52.8° C].
AGS LIMIT	Water temperature is above 140° F [60° C].
THERM FUSE OPEN	Thermal fuse circuit is open.
AIR FLOW FAULT	Air flow switch is open.
ICM FAULT	Ignition control module does not detect flame.
STACK FLUE HIGH	Stack flue sensor detects combustion gases above 185° F [85° C].
STACK FLUE OPEN	Stack flue sensor circuit is open.
STACK FLUE SHORT	Stack flue sensor short circuit.
CONDENSATE BLOCK	Condensate float switch detects water in exhaust stack.
REPLACE CNC	Condensate neutralizer cartridge's effective lifetime has expired. *
FREEZE WARNING	Ambient air temperature is too low for gas heater operation.

(* **Note:** To clear this alarm, press the DOWN arrow and MODE button simultaneously. The alarm may take a few moments to clear after the buttons are pressed.

Service Menu Tree Guide

(Press UP and DOWN Arrows Simultaneously)

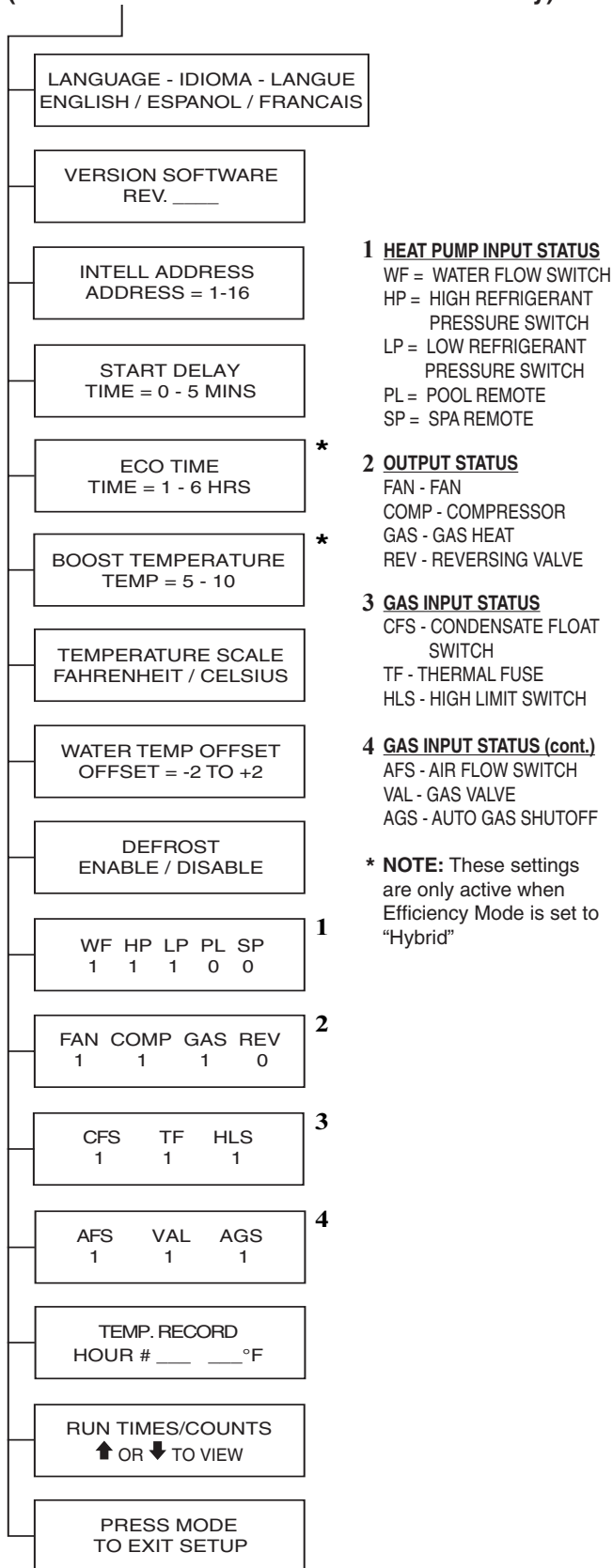

Navigating the Service Menu Screens

Press the UP and DOWN arrows simultaneously. If no activity is detected after 15 seconds, the display will return to the main screen.

Language Selection

Displays the language selected. Select either English, Spanish or French using the UP and DOWN arrows.

Software Revision

Displays the software revision level loaded on the control board.

Intell Address

Heater RS-485 Communications Address which must match the address used in the EasyTouch automation controller being communicated with. Adjustable from 1 to 16 using the UP and DOWN arrows.

Start Delay

Displays the time period between heater start cycles. Adjustable from 0 to 5 minutes using the UP and DOWN arrows.

Eco-Time

Displays the period of time the heat pump will attempt to reach an active set point before the gas heater activates. Adjustable from 1 to 6 hours using the UP and DOWN arrows.

Boost Temperature

Displays the temperature difference allowed between incoming water temperature and active set point. If the temperature difference exceeds this setting the gas heater will activate. Adjustable from 5-10 degrees using the UP and DOWN arrows.

Temperature Scale

Determines if the water temperature actual reading and set point is displayed in degrees Fahrenheit or Celsius. Adjusted between Fahrenheit and Celsius using the UP and DOWN arrows.

Temp Offset

Adjusts the measured water temperature up or down to allow the operator to match the heater's displayed temperature to a remote temperature monitoring device. The offset can be varied from -2 to +2 using the UP and DOWN arrows.

Defrost Screen

Allows the user to Enable/Disable Defrost feature.

1 Heat Pump Input Screen and Output Screen

2 Diagnostic displays showing the status of the input sensors and output devices. The number one (1) is displayed when the associated input/output is on and zero (0) is displayed when the associated input/output is off.

3 Gas Input Status Screens

4 Diagnostic displays showing the status of gas-related input sensors. The number one (1) is displayed when the associated input is on and zero (0) is displayed when the associated input is off.

Temperature Log and Run Time Counters

These screens display a list of compressor, fan and valve run times, and a history of measured water temperatures. This information is provided so the user can easily track performance and troubleshoot issues.

Exit Set Up

Pressing the MODE button while this screen is displayed returns the display to the Efficiency Mode Screen.

Using the Service Menus

Eco-Time

Note: The Eco-Time setting is only active when Efficiency Mode is set to “Hybrid”.

In some cases, the heat pump alone will be unable to heat incoming water to the active set point within a specific period of time. In these cases the gas heater will turn on to provide supplemental heat.

The Eco-Time setting is the period of time the heat pump will attempt to heat to the active set point before the gas heater activates to provide supplemental heat. Both the Pool Set Point and Spa Set Point have an individual Eco-Time setting.

To change the Eco-Time setting:

1. Press the UP and DOWN arrows simultaneously.
2. Press the MENU SELECT button repeatedly until the Eco-Time screen is displayed.

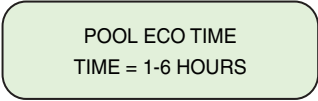

POOL ECO TIME
TIME = 1-6 HOURS

3. Press the UP or DOWN arrows to select the desired duration. The last value displayed will become active.

Boost Temperature

Note: The Boost Temperature setting is only active when Efficiency Mode is set to “Hybrid”.

In some cases the heat pump alone will be unable to heat incoming water to the active set point as a result of unusually low water temperature. If the difference between the actual incoming water temperature and the active set point exceeds a set amount, the gas heater will turn on to provide supplemental heat.

The Boost Temperature setting is the difference between incoming water temperature and the active set point which will activate the gas heater. Both the Pool Set Point and Spa Set Point have an individual Boost Temperature setting.

To change the Boost Temperature setting:

1. Press the UP and DOWN arrows simultaneously.
2. Press the MENU SELECT button repeatedly until the Boost Temperature screen is displayed.

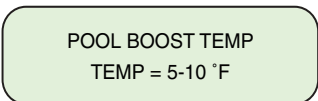

POOL BOOST TEMP
TEMP = 5-10 °F

3. Press the UP or DOWN arrows to select the desired temperature. The last value displayed will become active.

Temperature Scale - C° or F°

The control board can display temperatures in either degrees Fahrenheit or Celsius. The temperature scale in use can be changed from the Service Menu tree as described below:

1. Press the UP and DOWN arrows simultaneously.
2. Then press the MENU SELECT button repeatedly until the Temperature Scale screen is displayed.
3. Press the UP or DOWN arrows to toggle between the Fahrenheit and Celsius options. The last option shown on the display will become active.

Water Temperature Offset

The control board provides the ability to increase or decrease the displayed water temperature.

To change the temperature offset:

1. Press the UP and DOWN arrows simultaneously.
2. Press the MENU SELECT button repeatedly until the Temperature Offset screen is displayed.
3. Press the UP or DOWN arrows to select the desired offset. The last number shown on the display will become active.

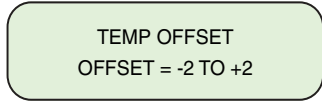

TEMP OFFSET
OFFSET = -2 TO +2

Defrost Cycle

The UltraTemp ETi™ Hybrid Heater may enter a defrost cycle if air temperatures are around 50°F (10°C). To enter a defrost cycle the Defrost feature must be enabled in the Service Menus.

The passive defrost cycle initiates when the evaporator sensor detects refrigerant temperature below the defrost set point. At this time, the heater compressor stops. The heater evaporator fan will continue to run, and will draw air over the evaporator fins for about 15 minutes.

If the refrigerant sensor detects a temperature above the defrost stop temperature, the compressor will restart. If defrost stop temperature is not reached within 15 minutes the unit will shut down and display a “Low Ambient Temp” alarm.

Run Time Counters

Details of the Run Time Counter abbreviations are listed below:

COMP = COMPRESSOR

FAN = EVAPORATOR FAN

REV VLV = REVERSING VALVE

DEFROST = DEFROST FEATURE

GAS = GAS HEATER

RUN TIME = total time of the current cycle

LOG TIME = accumulated time of all cycles since the last time the unit was powered on

CYCLES = number of cycles since the last time the unit was powered on

WARRANTY HOURS = accumulated time while the unit is powered on

WARRANTY CYCLES = number of cycles over the lifespan of the unit

Press the UP and DOWN arrows to scroll through the Timers and Counters. The last screen provides an option to reset the Run Time, Log Time and Cycles counters. The Warranty Hours and Warranty Cycle Counter cannot be reset.

Locking the Control Panel

1. Heater control panel lock-out – To prevent unwanted adjusting or manipulating of the heater settings, the control panel can be locked. Once locked, if any button is pressed, the display will read:

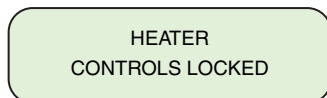

- To activate the control panel lockout, press the MENU SELECT and MODE buttons simultaneously.
- To unlock the control panel, press the MENU SELECT and MODE buttons simultaneously.

MAINTENANCE

Water Chemistry

Proper chemical balances are necessary for sanitary bathing conditions as well as prolonging to life of your UltraTemp ETi™ Hybrid Heater.

Be sure to keep your chemical and mineral concentration levels within the values indicated in the table below. Failure to maintain proper water chemistry may cause damage to the heater and may void the warranty.

When using a chlorinator, install it down stream from the heater and at a lower level than the heater outlet. Install a corrosion resistant positive seal check valve between the heater and the chlorinator to prevent concentrated chemicals from back-siphoning into the heater. Back-siphoning is most likely to occur when the pump stops, creating a pressure-suction differential.

Note: Do NOT sanitize the pool by putting chlorine tablets or sticks into the skimmer(s). When the pump is off, this will cause a high concentration of chlorine to enter the heater, which could cause corrosion damage to the heat exchanger.

Three major items that can cause problems with your pool heater are: total alkalinity, improper pH and disinfectant residual. These items, if not kept properly balanced, can shorten the life of the heater and cause permanent damage. See **Table 3**.

Table 3: Recommended Water Chemistry Ranges

Test	Recommended Level
Free Chlorine <i>or</i>	1.0 to 3.0 ppm (3.0 to 5.0 spa)
Bromine	2.0 to 4.0 ppm (3.0 to 5.0 spa)
pH	7.4 to 7.6
Total Alkalinity (TA) Calcium, Lithium, and Sodium Hydrochlorite	80 to 100 ppm
Total Alkalinity (TA) Sodium Dichlor, Trichlor, Chlorine Gas, and Bromine Compounds	100-120 ppm
Calcium Hardness (CH)	200 to 400 ppm
Cyanuric Acid	30 to 50 ppm
Total Dissolved Solids (TDS)	Less than 2000 ppm
Copper	0 ppm
* Concentration levels taken from "Basic Pool and Spa Technology" published by NSPI (National Spa and Pool Institute).	

Note: Failure to maintain levels below the top end of these ranges may result in premature failure of the heat exchanger and will void the warranty.

Total Alkalinity

Total alkalinity is a measurement of the total amount of alkaline chemicals in the water, and control pH to a great degree. It is not the same as pH which refers merely to the relative alkalinity/ acidity balance. Your pool water's total alkalinity should be 80 - 100 ppm to permit easier pH control. A total alkalinity test is simple to perform with a reliable test kit. You will need to test about once a week and make proper adjustments until alkalinity is in the proper range. Then, test only once every month or so to be sure it is being maintained. See your local pool dealer for help in properly balancing the water chemistry.

Balancing pH



Do not test for pH when the chlorine residual is 3.0 ppm or higher, or bromine residual is 6.0 ppm or higher. See your local pool supply store for help in properly balancing your water chemistry.

The term pH refers to the acid/alkaline balance of water expressed on a numerical scale from 0 to 14. Muriatic acid has a pH of about 0, pure water is 7 (neutral) and weak lye solution has a pH of 13-14. A test kit for measuring pH balance of your pool water is available from your local pool supply store.

If pH becomes too high (over alkaline), it has these effects:

1. Reduces the ability of chlorine to destroy bacteria and algae.
2. Water becomes cloudy.
3. Higher chance of scale formation on the plaster or in the heat exchanger tubing.
4. Filter elements may become blocked.

If pH is too low (over acid) the following conditions may occur:

1. Excessive eye burn or skin irritation.
2. Etching of the plaster.
3. Corrosion of metal fixtures in the filtration and recirculation system, which may create brown, blue, green, or sometimes almost black stains on the plaster.
4. If you have a sand and gravel filter, the alum used as a filter aid may dissolve and pass through the filter.

Disinfectant Residual

To neutralize algae and/or bacteria in the pool system disinfectant must be used. Both chlorine and bromine are universally accepted and approved disinfecting agents for control of bacteria and algae.

When chlorine or bromine are added to the system, a portion of the disinfectant will be consumed in the process of destroying bacteria, algae and other oxidizable materials. The disinfectant that is left behind is called either chlorine or bromine residual. These residual levels must be controlled to assure continuous kill of bacteria or viruses introduced into the system from swimmers, dust, rain and/or other sources.

Disinfectant residual can be determined by a reliable test kit purchased from your local pool supply store.

General Maintenance

Pentair recommends that you inspect your heater on a continual basis and especially after abnormal weather conditions. The following basic guidelines are suggested for your inspection:

1. Make sure the front of the unit is accessible for future service.
2. Ensure the top and surrounding areas of the heater are clear of all debris.
3. Ensure all plants and shrubs are trimmed and away from the heater.
4. Keep lawn sprinkler heads from spraying on the heater to prevent corrosion and damage.
5. Do not use this heater if any part has been under water. Immediately call a qualified professional technician to inspect the heater and replace any part of the control system which has been submerged.

Every six months and start of every pool season:

6. Test the operation of the pressure relief valve by lifting the valve lever (if installed).
7. Test for proper operation of the water pressure switch. See *Water Pressure Switch Adjustment* on page 23 for testing instructions.

Every year and start of every pool season:

8. A qualified service technician should inspect and clean the TitanTough™ Titanium Heat Exchanger assembly (see **Figure 24**).
9. A qualified service technician should inspect the burner, spark electrode, electrode wiring (not shown), flame sensor rod and thermal insulation for signs of damage or deterioration. (see **Figure 24**).

Condensate Drainage

The UltraTemp ETi™ Hybrid Heater will produce condensation (water) while the heat pump is in operation. The heater base is designed to allow the condensation to exit through the bottom drain port when the unit is running. The condensation will increase as the outdoor air humidity level increases. Check the following at regular intervals to ensure proper condensate drainage:

1. Visually inspect and clear the drainage connection and hose of any debris that could clog the ports. Refer to page 7, *Heat Pump Drainage Connection* to ensure the drain barb and hose are installed correctly.
2. Keep the top air flow discharge and air flow intake area clear of debris so the air flow through the heater is not restricted. The cooler discharge air from the top should not accumulate and be drawn into the side air intake coils.
3. Be sure the condensate run-off is properly directed away from the equipment pad to keep it from undermining the pad.
4. Be sure the condensate water does not puddle inside the heater. To be sure it is condensate water, check for the absence of chlorine.

During normal operation, the heat pump produces three to five gallons of condensate per hour. If condensate drainage is above this range during operation or if water continues to drain from the base when the heater is not in operation for more than an hour, a leak in the internal plumbing may have occurred. Call a qualified heater technician to investigate the problem.

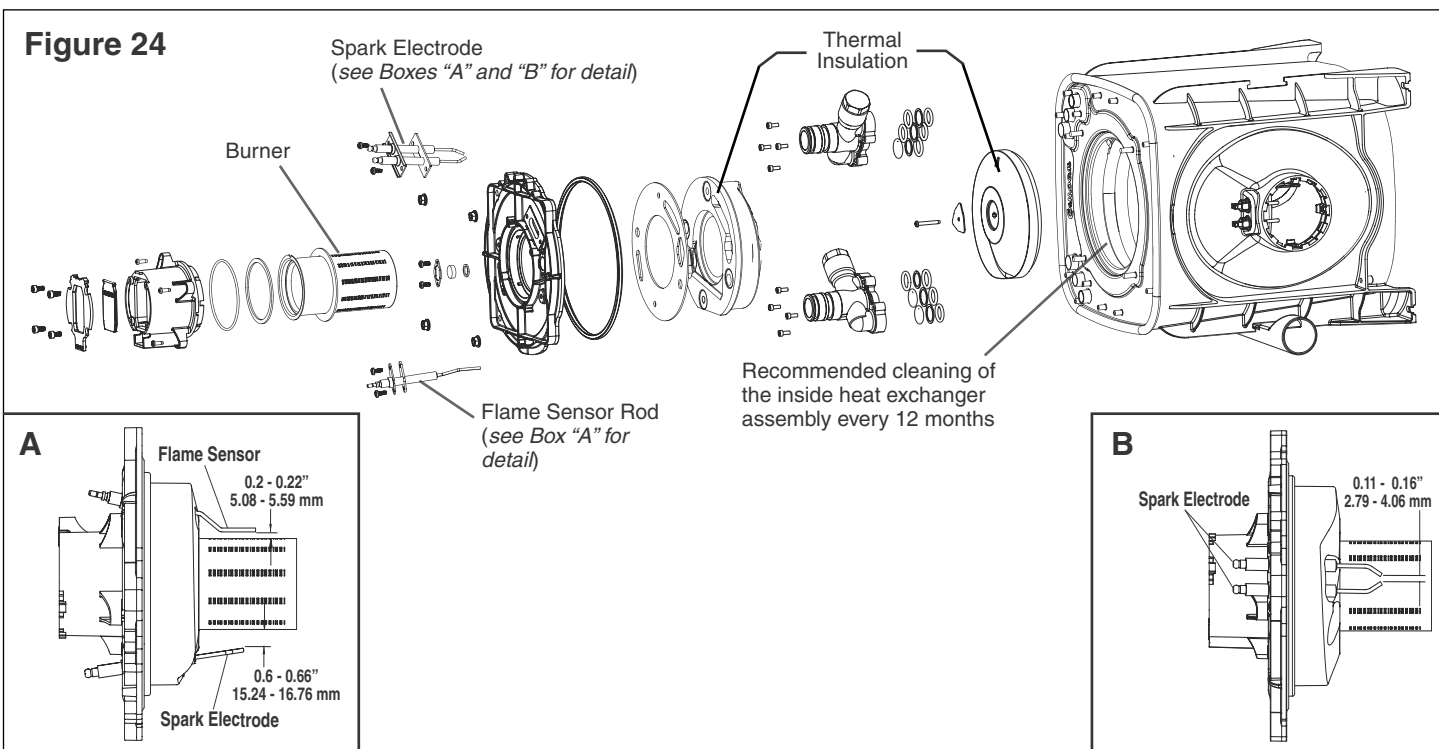

Winterizing

⚠ WARNING Separation hazard. Purging the system with compressed air can cause components to separate, with risk of severe injury or death to anyone nearby. Use only a low pressure (below 5 PSI or 35 kPa), high volume blower when air purging the heater.

⚠ CAUTION Failure to winterize could cause damage to the heater and will void the warranty.

⚠ CAUTION Water trapped in the heat exchanger can result in freeze damage to the exchanger or headers. Freeze damage is specifically not covered by the warranty.

⚠ CAUTION When starting the heater for the swimming season with a water temperature below 50° F (10° C), the heater may be used to heat the water; however, make sure that the heater operates continuously until the water temperature reaches the heater's minimum setting of 68° F (20° C). During cold weather, if there is no danger of freezing, operate the filter pump continuously even if the heater is not operating. If air temperatures are expected to drop below freezing (32° F/0° C), shut down the heater and winterize it.

In areas where freezing temperatures occur, you should protect your pump, filter, and heater from the elements. Perform the following steps to completely drain the heater.

1. Turn off the electrical power to the heater at the main breaker panel.
2. Close main gas control valve and manual gas valve.
3. Shut off the water supply to the heater.
4. Drain all water from the heater system.
5. Disconnect the water inlet and outlet unions from the system plumbing.
6. If the heater is below pool water level, be sure to close the isolation valves to prevent from draining the pool. Isolation valves are not required and should not be used on heaters installed above pool water level, except when needed for winterization valves.
7. Remove the black drain plug located to the right of the High Limit Switch (HLS).
Alternatively, disconnect the water management system at the two internal unions and quick release clips to partially drain, then reassemble.
8. Use a blower, connected to the outlet of the heater, to remove all remaining water from the heater.
9. Cover air inlet grate with a plastic bag to prevent bugs, leaves, etc., from getting into the heater.
10. Remove the hose barb from the condensate neutralizer cartridge outlet and drain all water from the cartridge and connected tubing.

Spring Start Up

If your heater has been winterized, perform the following steps when starting the system in the Spring:

1. Uncover the heater and inspect the top and sides for any debris or structural problems.
2. Connect the water inlet and outlet unions to the system plumbing. Ensure they are connected correctly and that there are no water leaks.
3. Place the drain plug back into the port in the water management assembly.
4. Reconnect the condensate neutralizer cartridge hose.
5. Turn on the electrical power to the heater at the main breaker panel.
6. Before starting the heater, circulate water through the heater for several minutes until all air noises stop. See also *Pre-Startup* (page 21) and *General Maintenance* (page 33).

Professional Maintenance and Service

The maximum heat output and efficiency of a heater is dependent upon the quality and performance of the major components used. Equally important are the environmental conditions (for example, air temperature, humidity, water temperature, and wind).

To maintain maximum performance and efficiency, keep the air coil clean from dirt and debris. It is recommended to clean your air coil once a year by flushing the coil with compressed air or hosing off the coil with a garden hose.

Care should be taken to not bend the coil fins as this will restrict the airflow and lower your heater performance. Compressed air can also damage the heater coil. **DO NOT USE A PRESSURE CLEANER ON THE UNIT.**

The heater should be maintained at least once a year by qualified personnel to maintain maximum performance and efficiency. The unit should be powered off during maintenance.

TECHNICAL DATA

Electrical Supply - Voltage Requirements

HEATER ELECTRICAL REQUIREMENTS	
Voltage/Phase/Hz	208-230/1/60
Min. Circuit Ampacity (Amp)	42
Recommended Fuse Size	50
Max Fuse Breaker Size	70
Compressor/Fan Motor/System RLA	32/2/34
Compressor/Fan Motor/System LRA	148/4/150
Compressor/Fan Motor/System MCC	50/NA/NA
Capacity (Btu/h) 80A-80RH-80W *	108,000
COP 80A-80RH-80W *	5.8
Power Input, KW (80A-80RH-80W) *	5.3
Current, Amp (80A-80RH-80W) *	24
Capacity (Btu/h) 80A-63RH-80W **	100,000
COP 80A-63RH-80W **	5.6
Power Input, KW (80A-63RH-80W) *	5.3
Current, Amp (80A-63RH-80W) *	24
Capacity (Btu/h) 50A-63RH-80W ***	70,000
COP 50A-63RH-80W ***	4
Power Input, KW (50A-63RH-80W) *	5.2
Current, Amp (50A-63RH-80W) *	23
Shipping Weight (lbs) ****	520
Shipping Size (L x W x H)****	58"x43"x52"

* 80A-80RH-80W: 80° F Air Temp, 80% RH, 80° F Water Inlet Temp.

** 80A-63RH-80W: 80° F Air Temp, 63% RH, 80° F Water Inlet Temp.

*** 50A-63RH-80W: 50° F Air Temp, 63% RH, 80° F Water Inlet Temp.

**** Includes shipping crate.

COP = Coefficient of Performance

If voltage drops below 208V, this may damage the heater and void the warranty. Take proper steps to ensure correct voltage at the heater during operation.

ENGLISH

Temperature Resistance Chart

WATER / DEFROST			
°F	OHMS	°F	OHMS
30	34,367	85	8,230
35	30,254	90	7,403
40	26,031	95	6,531
45	23,014	100	5,894
50	19,901	105	5,221
55	17,255	110	4,634
60	15,351	115	4,202
65	13,373	120	3,758
70	11,942	125	2,404
75	10,450	130	3,042
80	9,366		

STACK FLUE					
°F	OHMS	°F	OHMS	°F	OHMS
30	29,101	85	8,496	140	3,012
35	25,644	90	7,698	145	2,773
40	22,724	95	6,936	150	2,542
45	20,300	100	6,315	155	2,341
50	17,999	105	5,717	160	2,154
55	16,175	110	5,209	165	1,985
60	14,425	115	4,737	170	1,833
65	12,971	120	4,318	175	1,691
70	11,633	125	3,944	180	1,567
75	10,466	130	3,598	185	1,446
80	9,436	135	3,299		

Pressure Chart

The table below should be used by trained air-conditioning and refrigeration service people.

The table below **should not be used for adjusting the charge in the system.**

Use of interpolation or extrapolation of the table data may not be appropriate unless it is closely matched by the ambient and water flow conditions.

Operating Environment	Discharge Pressure (PSig)	Suction Pressure (PSig)	Superheat (°F)
Air: 80°F, 80%RH Water: 80°F, 45-50 GPM	340	166	10
Air: 80°F, 63%RH Water: 80°F, 45-50 GPM	337	155	8
Air: 50°F, 63%RH Water: 80°F, 45-50 GPM	320	94	2
Air: 80°F, 63%RH Water: 104°F, 45-50 GPM	450	159	4

RH = Relative Humidity

Pressure Drop Curves

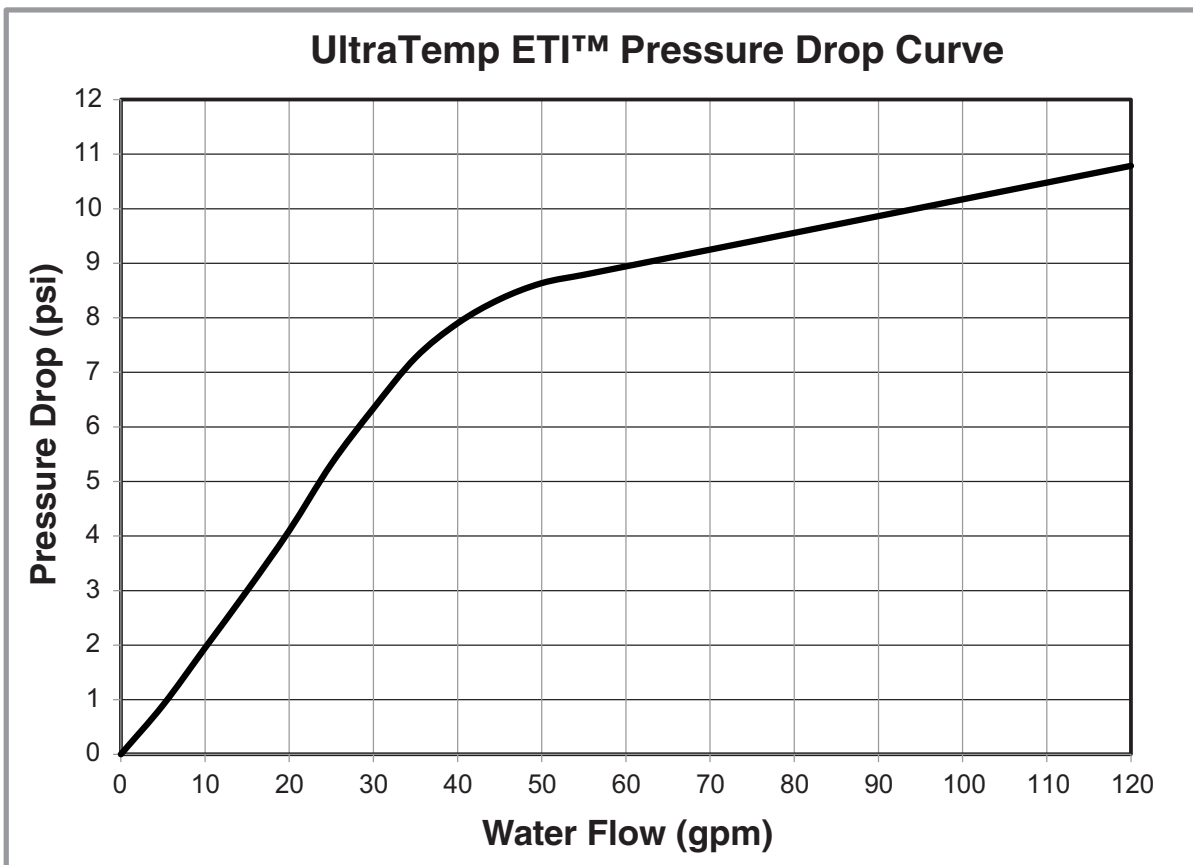

TROUBLESHOOTING



RISK OF ELECTRICAL SHOCK OR ELECTROCUTION.

Improper installation will create an electrical hazard which could result in death or serious injury to pool users, installers, or others due to electrical shock, and may also cause damage to property. Do NOT attempt any internal adjustments inside the heater.



1. Keep your hands and hair clear of the fan blades to avoid injury.
2. If you are not familiar with your pool filtering system and heater:
 - a. Do NOT attempt to adjust or service without consulting your dealer, professional pool or air conditioning contractor.
 - b. Read the entire Installation & User's Guide before attempting to use, service or adjust the heater or pool filtering system. The water pressure switch should be adjusted to turn the heater off when the pump is off. Setting the switch to close at too low of a flow can damage the appliance. Adjust the switch to turn the heater off, not on.

Always turn power to the unit OFF before servicing or repair.

Note: Any service must be done by an authorized service agency person.

Problem or Symptoms	Possible Cause	Corrective Action
CONTROL PANEL ALARMS		
HIGH WATER TEMP Alarm: Water temperature above 104° F [40° C].	Bad thermistor, connection or control board.	Test water temp to see if it is correct, if not, use the 10k ohm resistance test to verify thermistor. If bad, replace thermistor. If good, replace control board.*
LOW WATER TEMP Alarm: Water temperature below 40° F [4.4° C].	Bad thermistor or bad control board. Debris is shorting the connections.	Test water temp to see if it is correct, if not, use the 10k ohm resistance test to verify thermistor. If bad, replace thermistor. If good, replace control board.* Remove debris or replace PCB.
LOW WATER FLOW Alarm: The pressure switch sensing water flow is open.	1. Water circulation pump not on.	Verify water circulation pump is on.
	2. Insufficient water flow.	Dirty or worn filters or clogged lint traps. Verify filter is clean, backwash if necessary to clean entire filter system or replace filter element if needed. Inspect & clean pump impeller. Adjust Plumbing valves. Repair suction air leaks.
	3. External bypass open.	Make sure external water bypass around heater is closed.
	4. Bad water pressure switch.	With water flowing, check resistance of water pressure switch, if open, replace switch.
REMOTE POOL SPA Alarm: Pool and Spa remote inputs are simultaneously energized.	Remote pool, spa, and common spade terminals on the back of the control board are all energized.	Modify automation control output so that only either the pool and common or spa and common terminals are energized.
WATER THERM SHORT Alarm: Water temperature sensor circuit is shorted.	Bad thermistor or bad control board.	Use the 10k ohm resistance test to verify thermistor. If shows shorted, replace thermistor. If good, replace control board.*
WATER THERM OPEN Alarm: Water temperature sensor circuit is open.	Bad thermistor, or bad control board.	Use the 10k ohm resistance test to verify thermistor. If shows open, replace thermistor. If good, replace control board.*
SUCTION TH SHORT Alarm: Defrost refrigerant temperature sensor circuit is shorted.	Bad thermistor or bad control board.	Use the 10k ohm resistance test to verify thermistor. If shows shorted, replace thermistor. If good, replace control board.*
SUCTION TH OPEN Alarm: Defrost refrigerant temperature sensor circuit is open.	Bad thermistor or bad control board.	Use the 10k ohm resistance test to verify thermistor. If shows an open, replace thermistor. If good, replace control board.*
BROWNOUT Alarm: The 24 VAC supply voltage to the control board is low. CAUTION: High Voltage Checks. Observe extreme caution or call dealer or factory for advice before attempting to Troubleshoot Electrical Box.	1. Bad transformer	Supply voltage to the transformer should be between 208 and 240 volts. Transformer should output between 22 and 28 volts. If below this range, replace transformer.
	2. Insufficient supply voltage to the heater.	Check supply voltage to the heater. Supply voltage should be between 208 and 240 volts. Check to see if a phase is out. A boost transformer may be needed closer to the heater to get voltages within proper range.

*Refer to 10K Ohm Temperature Resistance Chart on page 35.

Problems or Symptoms	Possible Cause	Corrective Action
HIGH REFRIG Alarm: Refrigerant high pressure switch is open.	1. Water circulation pump not on.	Verify water pump is on.
	2. Insufficient water flow.	Verify filter and skimmers are clean, backwash if necessary. Minimum flow 30 GPM [113.6 LPM].
	3. External bypass open.	Verify external water bypass around heater is closed. Also make sure all other valves are open or in the proper positions to allow proper water flow through heater.
	4. Bad refrigerant high pressure switch.	Call for professional servicing.
	5. TXV Stuck Closed.	Call for professional servicing.
	6. Other Possibilities:	Check Water level in pool. This condition may appear if the heater has NOT been operated for an extended period. To Clear this condition, cycle the heater on and off up to 3 times. If this does not correct problem, call for service.
	7. Other Possibilities. Low or restricted water flow through heater. Dirty or worn filters or clogged lint traps. Clogged filter pump impeller. Improper plumbing valve settings. Suction leak allowing air into the water flow. Unit is plumbed backwards. Heat exchanger clogged with debris. Internal bypass valve damaged or clogged with debris.	Clean entire filtering system and or replace filter element. Inspect & clean pump impeller. Adjust all plumbing valves. Repair suction air leaks, grease pump lid O-ring. Replace filter. Wrong filter pump pipe size. Automatic pool vacuum causing restriction. Call your dealer or factory for advice if above does not solve the problem.
	8. Unit overcharged.	Call for professional servicing.
LOW REFRIG Alarm: Refrigerant low pressure switch is open.	1. Low refrigerant in system.	Call for professional servicing.
	2. Air and water temperatures too cold to operate the heater.	Wait until temperatures warm up and see if unit operates.
	3. Bad refrigerant low pressure switch.	Check resistance of switch with a full charge, if open, replace switch.
	4. Faulty fan.	Check the capacitor and fan motor. Replace either one if it is faulty. Check the fan blade and make sure it is not slipping or broken. If so, replace the fan.
	5. TXV Stuck Closed.	Call for professional servicing.
	6. Insufficient airflow through air coil.	Remove surrounding debris or shrubs or heater maintenance by qualified personnel.
FIVE ALARMS: Indicates 5 faults have occurred in 1 hour. This fault will automatically reset in one hour or can be manually reset by pressing the ON/OFF button.	5 alarms of any kind within one hour.	Press the ON/OFF button to clear the alarm. Check Heater over the next few minutes/hours to see if alarm appears again. This alarm most likely caused the five alarms in one hour.
HI LIMIT SWITCH: Water temperature is above 127° F [52.8° C].	1. Insufficient water flow	Increase pump speed or flow setting. Water flow obstruction. Verify proper flow to heater. Refer to LOW WATER FLOW Alarm troubleshooting. Internal bypass valve stuck open. Repair or replace internal plumbing.
	2. Excessive inlet water temperature	Verify inlet water temperature is below 104° F [40° C]. Refer to HIGH WATER TEMP Alarm Troubleshooting
	3. High limit switch wiring faulty	Verify high limit switch connections in low voltage box. Clean or replace terminals.
	4. High limit switch faulty	Check for continuity between switch terminals with water temperature below 100° F [37.8° C]. Replace high limit switch if faulty.

Problems or Symptoms	Possible Cause	Corrective Action
AGS LIMIT: Water temperature is above 140° F [60° C].	1. Insufficient water flow, excessive inlet water temperature	Verify proper flow to heater. Refer to HI LIMIT SWITCH Alarm troubleshooting.
	2. Automatic gas shutoff switch connections faulty	Verify connections at switch and in low voltage box. Clean or replace terminals.
	3. Automatic gas shutoff switch faulty	Check for continuity between switch terminals with water temperature below 120° F [48.9° C]. Replace automatic gas shutoff switch if faulty.
THERM FUSE OPEN: Thermal fuse circuit is open.	Excessive stack flue temperature without LOW WATER FLOW, HI LIMIT SWITCH, AGS LIMIT, or STACK FLUE HIGH Alarm	Call technical support.
AIR FLOW FAULT: Air flow switch is open CAUTION: High Voltage Checks. Observe extreme caution or call dealer or factory for advice before attempting to Troubleshoot Electrical Box.	1. Air flow restriction in combustion system	Clear obstruction from blower inlet or exhaust stack / vent. Dust, soot or pollen buildup in heat exchanger. Remove burner and clean coils. Degraded insulation inside combustion chamber obstructing coils. Replace insulation and clean coils.
	2. Faulty air flow switch tubing	Verify vinyl tubing between air flow switch and blower is not disconnected, kinked, cracked, torn or punctured. Replace as necessary.
	3. Faulty blower or blower wiring	Disconnect blower at connector. On ignition try, verify line voltage at pins 1 and 3 of harness connector. If voltage checks ok, replace blower. If not present refer to Faulty Ignition Control Module (wiring) troubleshooting below.
	4. Faulty ignition control module wiring	Verify 24 VAC at ignition control module terminal 24 VAC. Verify line voltage at ignition control module terminal L1 and compressor contactor T2. Replace harness if faulty. If not, refer to Faulty Ignition Control Module troubleshooting below.
	5. Faulty ignition control module	On call for heat, If blower does not run. With mains power off, disconnect blower at connector and check continuity between blower harness connector pin 1 and ignition control module terminal F2. On call for heat, if blower starts but shuts off within 30 seconds refer to Faulty Air Flow Switch or Switch Wiring troubleshooting below.
	6. Faulty air flow switch or switch wiring	With mains power off verify connection at switch and at TH and IND terminals on ignition control module. Check connection at TB-GI-4. Clean or replace terminals. Replace air flow switch if faulty.
ICM FAULT: Ignition control module does not detect flame CAUTION: High Voltage Checks. Observe extreme caution or call dealer or factory for advice before attempting to Troubleshoot Electrical Box.	1. Inadequate gas supply	On call for heat heater does not fire, or fires but does not stay running. Verify incoming gas supply line size and pressure. Verify gas supply line is properly purged of air. Call technical support.
	2. Faulty gas valve	On call for heat, verify 24 VAC at gas valve terminal. Verify gas valve is switched ON. Call technical support to replace valve with identical part if faulty.
	3. Faulty gas valve wiring	Check continuity between gas valve ground and TB-O-1 terminals. On call for heat, verify 24 VAC at gas valve terminal. Clean or replace wiring terminals at valve if faulty. Repair or replace wiring harness if faulty.
	4. Faulty flame sensor wiring	On call for heat heater fires but does not stay running. With mains power off, check continuity between ignition control module terminal S1 and flame sensor rod. Clean or replace terminal. Repair or replace wire if faulty.
	5. Flame sensor rod does not detect flame	Verify distance between the flame sensor rod to burner. Refer to Figure 24 , page 33. Inspect rod for excessive solids buildup on surface, clean or replace if faulty.
	6. Faulty spark igniter wiring	Inspect igniter wires for signs of tearing or cracking of outer casing and boots. Replace igniter wires if degraded.
	7. Faulty spark igniter, igniter wires or ignition control module	On call for heat, check for proper spark operation with ignition spark tester. Replace igniter, wires or ignition control module if faulty.
	8. Spark electrode rods do not ignite gas	Verify the distance between the spark electrode rods, and spark electrode and the burners. Refer to Figure 24 , page 33. Inspect electrode rods for excessive solids buildup on surfaces, clean or replace if faulty.

Problems or Symptoms	Possible Cause	Corrective Action
STACK FLUE HIGH: Stack flue sensor detects combustion gases above 185° F [85° C].	1. Air flow restriction in combustion system	Clear obstruction from exhaust stack / vent.
	2. High stack flue temperature without LOW WATER FLOW, HI LIMIT SWITCH, AGS LIMIT	Verify proper flow to heater. Ensure all isolation valves are open. Refer to LOW WATER FLOW Alarm troubleshooting.
	3. Poor heat transfer to water due to excessive scaling or solids buildup in heat exchanger	Call technical support. Correct pool / spa water chemistry.
	4. Poor heat transfer to water due to degraded insulation inside heat exchanger	Inspect chamber insulation for deterioration as evidenced by large surface irregularities or missing pieces and replace if faulty.
STACK FLUE OPEN: Stack flue sensor circuit is open.	1. Faulty stack flue sensor or wiring	Disconnect stack flue sensor at connector and use 401k ohm resistance test to verify wiring at sensor connection and at control board connection. If control board indicates about 77° F [25° C] replace sensor. If display indicates abnormally low value inspect and replace wiring.
	2. Faulty control board	Disconnect stack flue sensor connector at control board. Use 401k ohm resistance test at control board connection to verify board function. Display should indicate about 77° F [25° C]. If display indicates abnormally high or low value replace control board.
STACK FLUE SHORT: Stack flue sensor short circuit.	Faulty stack flue sensor or wiring	Inspect stack flue sensor connector for excessive moisture. Disconnect stack flue sensor at connector and on call for heat see if alarm changes to STACK FLUE OPEN . Replace sensor. Refer to STACK FLUE OPEN Alarm troubleshooting for wiring.
CONDENSATE BLOCK: Condensate float switch detects water in exhaust stack. CAUTION: High Voltage Present. Observe extreme caution or call dealer or factory for advice before attempting to Troubleshoot Electrical Box.	1. Heater condensate drain hose restriction	Verify proper hose routing from heater base. Ensure there are no loops, kinks or elevated portions between hose exit and heater base. Correct as necessary.
	2. Condensate drainage frozen due to operation in freezing temperatures	Shut down and properly winterize heater.
	3. Algae or solids buildup in float switch, neutralizer cartridge or connected hose	Shake cartridge to breakup accumulation. Remove switch and verify function. Clean or replace if necessary.
	4. Faulty float switch	Disconnect switch at connector and check for continuity between switch terminals while activating switch. Replace float switch if faulty.
	5. Faulty float switch wiring	With mains power off, check continuity between gas relay terminal 4 and TB-GI-1 in low voltage box. Repair or replace wiring if faulty.
	6. Faulty gas valve relay wiring	With mains power off, check continuity between ignition control module terminal 24 VAC and gas relay terminal 2. Check continuity between ignition control module B.GND and gas relay terminal 3. Check continuity between gas relay terminal 1 and TB-O-5. Repair or replace wiring if faulty.
	7. Faulty gas valve relay	On call for heat, check for 24 VAC at gas relay terminal 1 to determine if relay is being actuated. On call for heat, check for continuity between relay terminals 2 and 4 to determine if relay is functioning. Replace relay if faulty.
REPLACE CNC: Condensate neutralizer cartridge's effective lifetime has expired.	Heater run time has met service interval for condensate neutralizer cartridge	Check pH of gas heater condensate. Replace as necessary and reset alarm / counter.★
FREEZE WARNING: Ambient air temperature is too low for gas heater operation.	Heater is attempting to run in below freezing temperatures	Shut down and properly winterize heater.
	Faulty stack flue sensor or wiring	If control board display indicates abnormally low stack flue temperature value refer to STACK FLUE OPEN Alarm troubleshooting.

★To clear this alarm, press the DOWN arrow and MODE button simultaneously. The alarm may take a few moments to clear after the buttons are pressed.

Problem or Symptoms	Possible Cause	Corrective Action
GENERAL ISSUES		
Unable to turn Heater ON. Display is Blank. Unit will NOT start.	Control failure. No power supply to heater. Tripped breaker or blown fuse. Faulty Transformer. Incorrect Wiring.	Reset breaker. Replace fuse. Call professional serviceman to inspect transformer. Check wiring.
Unit power is ON, green light ON, and Set Temperature is above Actual. Unit will NOT start to heat. No Alarms.	Remote feature enabled, but no controlling device hook-up. Control failure.	Check to see if the Remote feature on the Control Board is enabled. Disable if needed. See Remote Mode, on pages 26-27, for more information on disabling Remote function. Call professional service person to check Control Board.
	Heater pool/spa selection mode incorrect. The thermostat is malfunctioning. Control Board Failure.	Check to see if heater is in correct active pool/spa mode.
Unit is forming ice or frost on the outer air coil, usually at the bottom.	Discharge air flow is restricted. Discharge air is accumulating and being drawn back through the outer air coil. The fan is obstructed, low air flow. Sprinklers spraying on the outer air coil during cooler temperatures. Outer air coil clogged with debris. Plants too close to heater, blocking discharge air flow. Low refrigerant pressure caused by a Refrigerant leak. Possible malfunctioning of the internal low refrigerant pressure switch. Check Alarm Status on Control Board for LOW REFRIG Alarm.	The outside air temperature too low and Defrost feature is NOT enable. Malfunctioning Defrost Thermistor. Make sure heater is installed with the required placement clearances for air flow and roof clearance. Do NOT install indoors. Make sure that your sprinklers do NOT spray on the heater in any way what so ever. If ice forms on the outer coil, shut the heater off and allow ice to thaw. You may use water at low pressure to thaw ice build up on the outer coil, shut the heater off when doing so. Call your dealer or factory for advice corrective action does not solve the problem.
Unit power is ON, and Set Temperature is above Actual. Fan is NOT Turning. No Alarms.	Faulty Fan Relay. Faulty Capacitor. Faulty Fan Motor. Control Board Failure. Incorrect wiring.	Call dealer for advice before attempting to replace parts. Replace Fan relay. Replace Capacitor, Replace Fan motor. Replace Control Board.
Fan is turning, no cool air discharge out of top of heater. Unit ON, and Set Temperature is above Actual, but Unit is not heating. No Alarms.	Heater is in the five minute safety delay and Compressor has not started. Faulty Compressor. Faulty Capacitor. Compressor contactor is stuck open. Control Board failure. Incorrect wiring.	Call dealer or factory for advice before attempting to replace parts. Replace Capacitor. Replace Control board. Replace Contactor. Replace Compressor.
Spa will not heat to maximum temperature of 104°F (40°C). OR Spa is heating very slowly.	Low or restricted water flow through heater. Dirty or worn filters or clogged lint traps. Clogged filter pump impeller. Improper plumbing valve settings. Suction leak allowing air into the water flow. Unit is plumbed backwards. Heat exchanger clogged with debris. Internal bypass valve damaged or clogged with debris. Air blower is running. Venturi air inlets are open. It is very cold outside. Spa pump is not running.	Clean entire filtering system and or replace filter element. Inspect & clean pump impeller. Adjust all plumbing valves. Repair suction air leaks, grease pump lid O-ring. Shut off air blower and or Venturi inlets that allow air turbulence in the spa. Use a cover while heating the spa. Outside air temp. too cold. Set spa pump timer for longer time. Call your dealer for advice. Call the factory for advice.
Pool is heating very slowly. Pool is not getting up to temperature.	"Low or restricted water flow through heater. Dirty or worn filters or clogged lint traps. Clogged filter pump impeller. Improper plumbing valve settings. Suction leak allowing air into the water flow. It is cold outside. Pool pump timer is not set for a long enough running period. Pool is not covered. High wind speed over pool. Shaded pool area."	Clean entire filtering system and or replace filter element. Inspect & clean pump impeller. Adjust all plumbing valves. Repair suction air leaks, grease pump lid O-ring. Use a pool cover. Place a wind break around pool. Set pool pump timer longer. Call your dealer for advice. Call the factory for advice.
Higher than Normal Head Pressure, lower than normal suction pressure with high superheat and very cold or frosty distributor tubes, may have no Alarm	TXV stuck closed.	<ol style="list-style-type: none"> 1. Disconnect TXV bulb from suction line (SL), have it in your hand, if pressures go back to normal, then reinstall the bulb on suction line (it may have some debris stuck in the port). For adjustable TXVs open adjustable valve, it may remove the debris and set it back to original position. 2. If (1) does not work, recover the charge, remove bulb from SL, unscrew TXV head, shake it, if rattles, replace head (PN KT-45-ZGA), if not, replace TXV and filter dryer and charge appropriately.

Problem or Symptoms	Possible Cause	Corrective Action
Lower than Normal Head Pressure, higher than normal suction pressure with cold suction line and compressor and no superheat, may have no Alarm.	TXV stuck open.	1. Check to see if TXV bulb is firmly attached to suction line, if loose, attach firmly by tightening the clamp over the bulb and suction line. 2. If (1) above does not work, reclaim charge and replace TXV and filter dryer with nameplate charge.
Unusually higher than normal current.	TXV stuck closed/partially closed, insufficient water flow, system overcharged.	See Possible Cause column for: TXV stuck closed, Insufficient water flow, and Unit overcharged.
Low current with high superheat.	Unit undercharged.	Find source of refrigerant leak and fix. Pull vacuum and charge.
Unit runs, but breaker trips continuously.	Electrical issue.	Contact certified electrician.
BURNER TROUBLESHOOTING		
Loud, high pitched whine	Flame is too rich.	Verify pressure tap between gas valve and blower inlet. See page 11 and verify that the gas regulator setting is -0.2" (-0.5cm) wc. Contact a qualified technician or service agency to replace the gas orifice.
Flame is "fluttery." Exhaust may have acrid smell or burner may fail to remain lit.	Flame is too lean.	See page 11 and verify that the gas regulator setting is -0.2" (-0.5cm) wc. Contact a qualified technician or service agency to replace the gas orifice.
Combustion appears normal, but flame does not stay lit.	Flame current is not being sensed.	Check for wet or damaged igniter with low resistance to ground. Replace with new ignitor if necessary. Verify burner flameholder is properly grounded. Replace ignition control module.
GAS HEAT EXCHANGER TROUBLESHOOTING		
Boiling in heat exchanger. May be accompanied by "bumping" sounds.	1. Low water flow to heater.	Service pump and/or filter.
	2. Heat exchanger plugged.	Service heat exchanger. Correct water chemistry.
	3. Bypass valve stuck open.	Service bypass valve.

REPLACEMENT PARTS

Heater Parts Breakdown

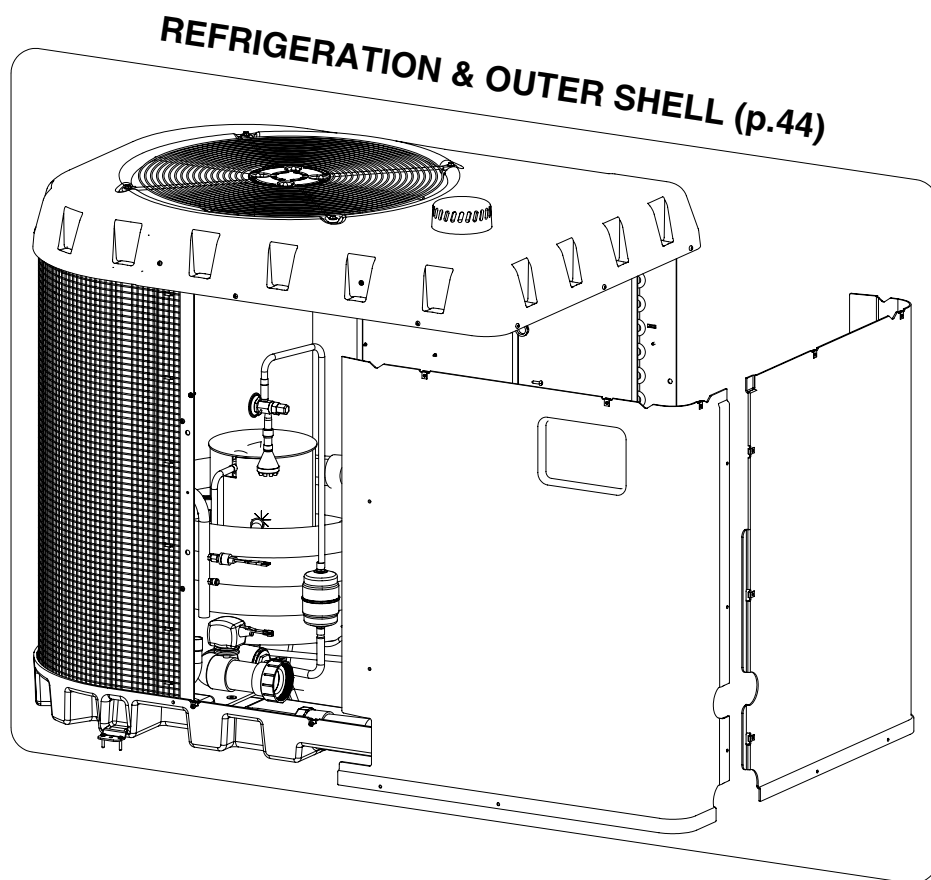

GAS SYSTEM (p.45)

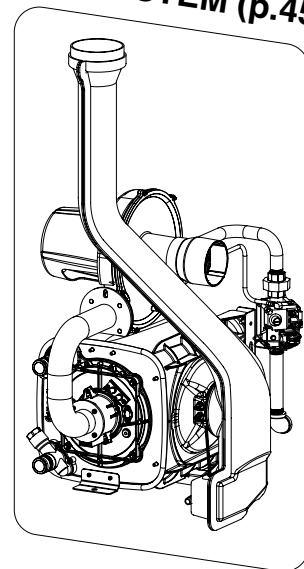

ELECTRICAL (p.46)

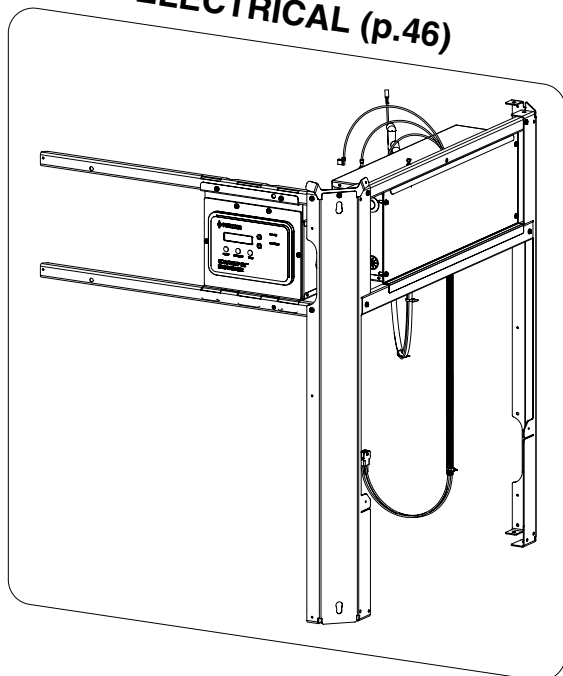

PLUMBING (p.47)

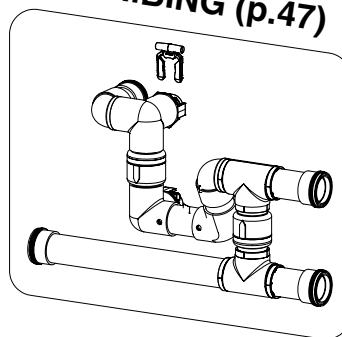

Parts List - Refrigeration and Outer Shell

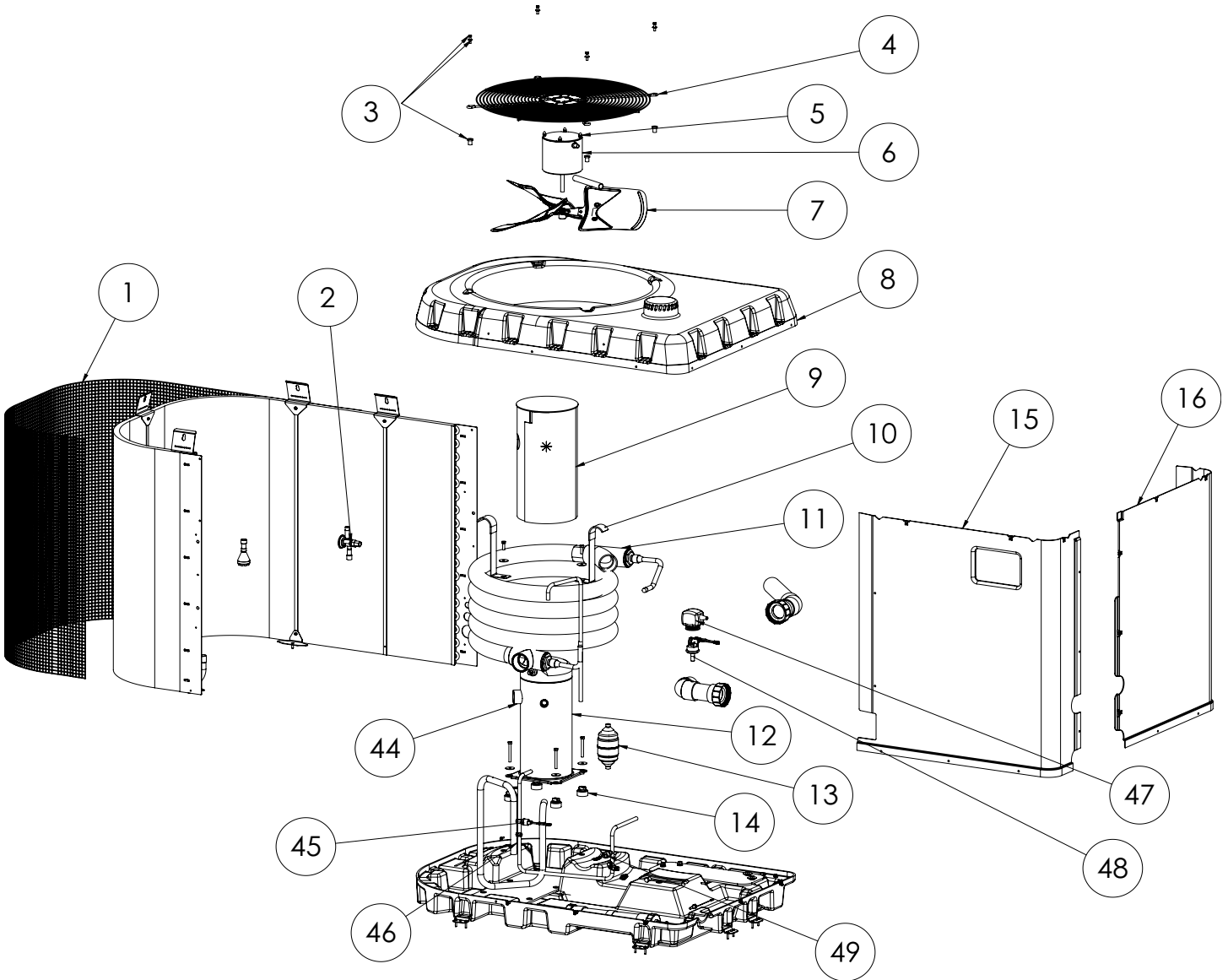

Item #	Part #	Description
1	473054Z	Coil Guard
2	476105Z	Thermostatic Expansion Valve
3	470441	Fan Guard Fastener Kit
4	473786	Fan Guard
5	470439	Nut, #10-32 SS Acorn
6	474030Z	Fan Motor with Acorn Nut Kit
7	473783	Fan Blade
8	475938Z	Hybrid Lid Almond
	476068Z	Hybrid Lid Black
9	475230Z	Compressor Blanket
10	475948Z	Titanium Heat Exchanger Tie Down Bracket
11	475949Z	Titanium Heat Exchanger
12	473735Z	Compressor, ZP70

Item #	Part #	Description
13	473121	Drier Single Direction
14	473736	Compressor Isolation Kit
15	475939Z	Control/HP Panel Almond
	476069Z	Control/HP Panel Black
16	475940Z	Gas Panel Almond
	476070Z	Gas Panel Black
44	474237	Compressor Harness Clip
45	473656	Switch, Low Refrigerant Pressure
46	473665	Probe Thermistor, Defrost Sensor
47	473606	Water Pressure Switch Boot
48	475956Z	Water Pressure Switch
49	473744	Switch, High Refrigerant Pressure
-	475232	Male Hose Barb, 5/8" x 1/2" NPT

Parts List - Gas System

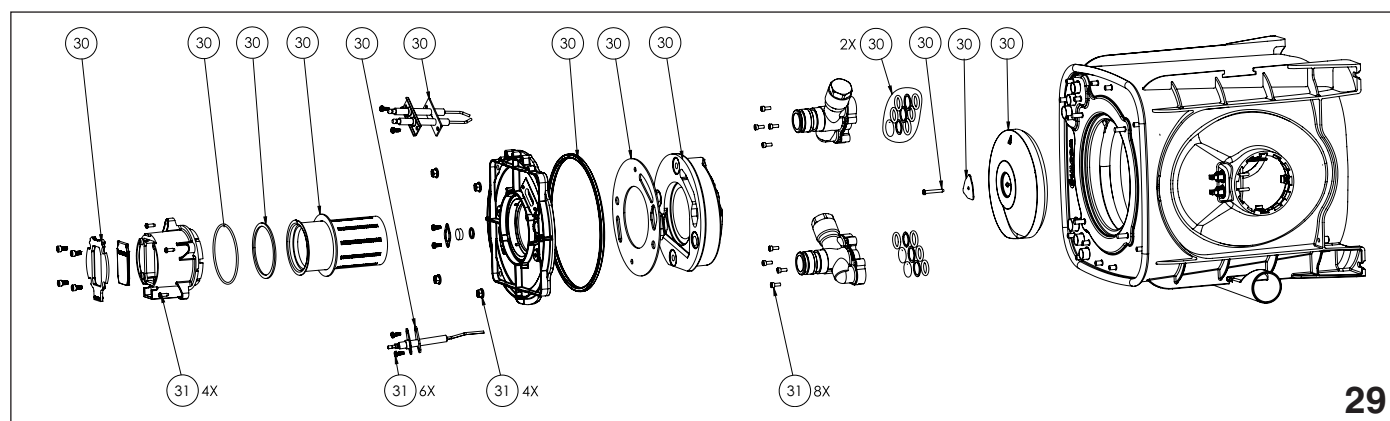
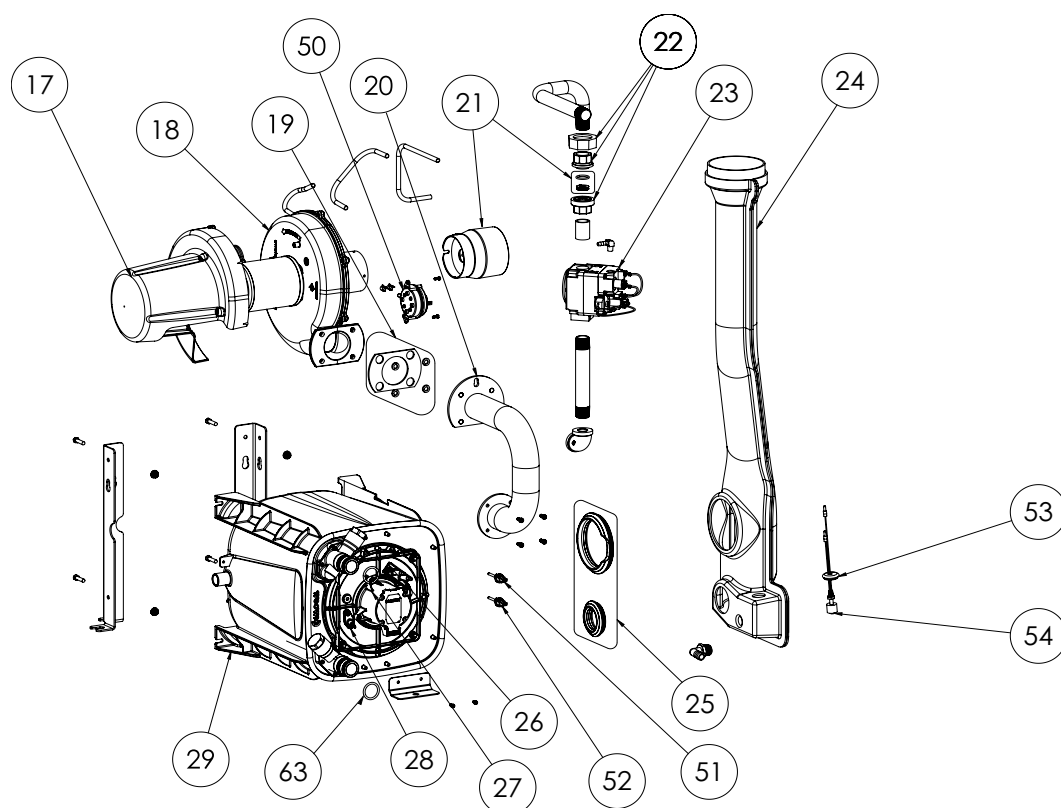

Item #	Part #	Description
17	475918Z	Blower Shield Replacement Kit
18	474285Z	Blower Kit, ETi 220
19	475902Z	Air Manifold to Blower Gasket Kit
20	475899Z	Air Manifold
21	475914	Orifice Kit, Natural Gas
	475871	Orifice Kit, Propane
22	38404-4097S	3/4 in. Union
23	476104Z	Gas Valve
24	475900Z	Exhaust Replacement Kit
25	475877	Exhaust Gasket Kit (2 Pieces)
26	475989	Gas Engine Spark Electrodes
27	475898	Burner Assembly
28	462023	Flame Sensor

Item #	Part #	Description
29	475897Z	Heat Exchanger, 100K BTU/hr
30	475919	Gas Heat Exchanger Gasket Service Kit
31	475920	Gas Heat Exchanger Hardware Kit
50	475987	Air Flow Switch Kit
51	476118Z	Thermal Fuse Replacement Kit
52	475601	Stack Flue Sensor
53	475911Z	Condensate Float Switch Bushing
54	475901Z	Condensate Float Switch
63	475912Z	Gas Engine Brass Ftg O-ring, -215 Silicone
-	475618	Pressure Relief Valve Kit
-	475954Z	Condensate Neutralizer Kit

(-) Not Shown

Parts List -- Electrical

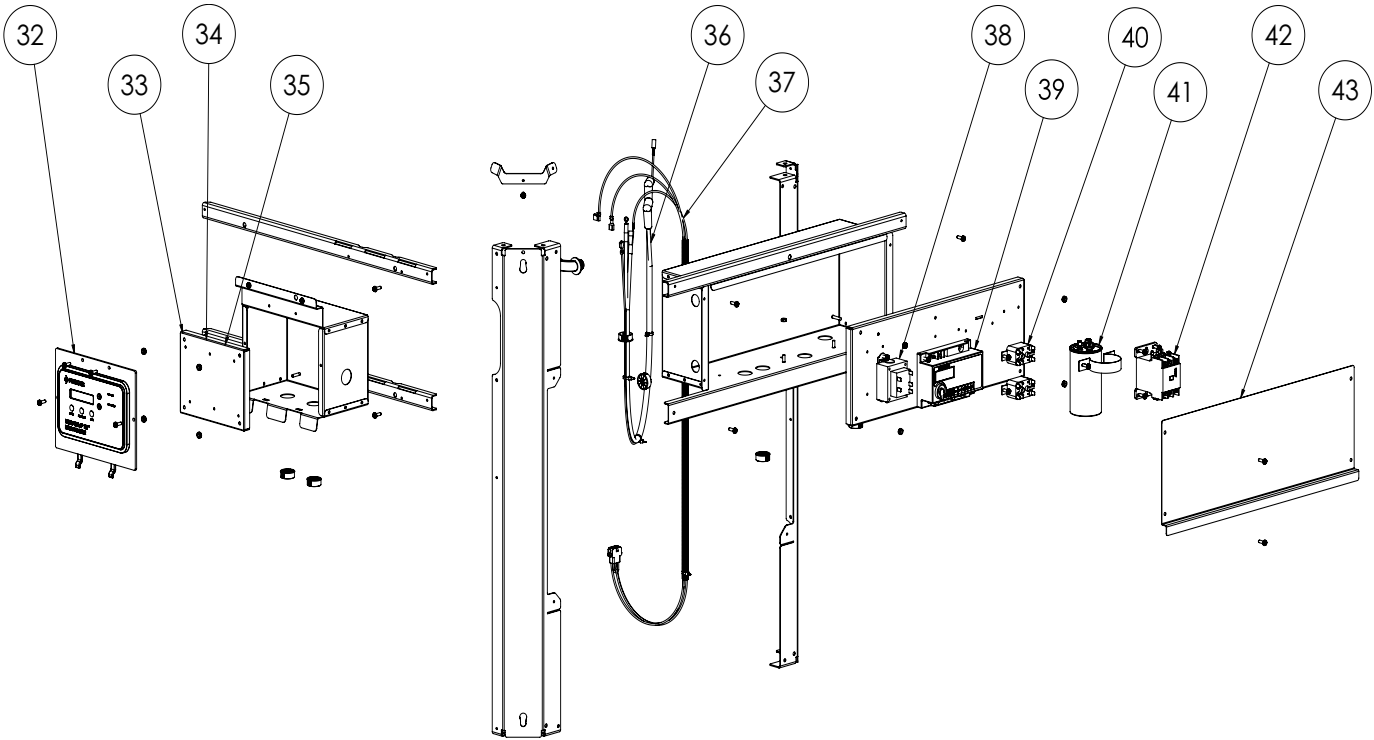

Item #	Part #	Description
32	475957Z	Bezel, Control Board, and Label Kit
33	475928Z	Wire Harness, Gas Inputs
34	475929Z	Wire Harness, Heat Pump Inputs
35	475930Z	Wire Harness, Outputs
36	475926Z	Wire Harness, Spark Plugs
37	475931Z	Wire Harness, Gas Blower
38	473155	Transformer
39	475933Z	Ignition Control Module

Item #	Part #	Description
40	473150	Relay, Fan and Gas
41	473731	Dual Capacitor
42	473149	Contactor Compressor/Input Power
43	475905Z	Cover Panel, High Voltage Box
-	475927Z	Wire Harness, High Voltage
-	475932Z	Compressor Harness, Hybrid

(-) Not Shown

Parts List -- Plumbing

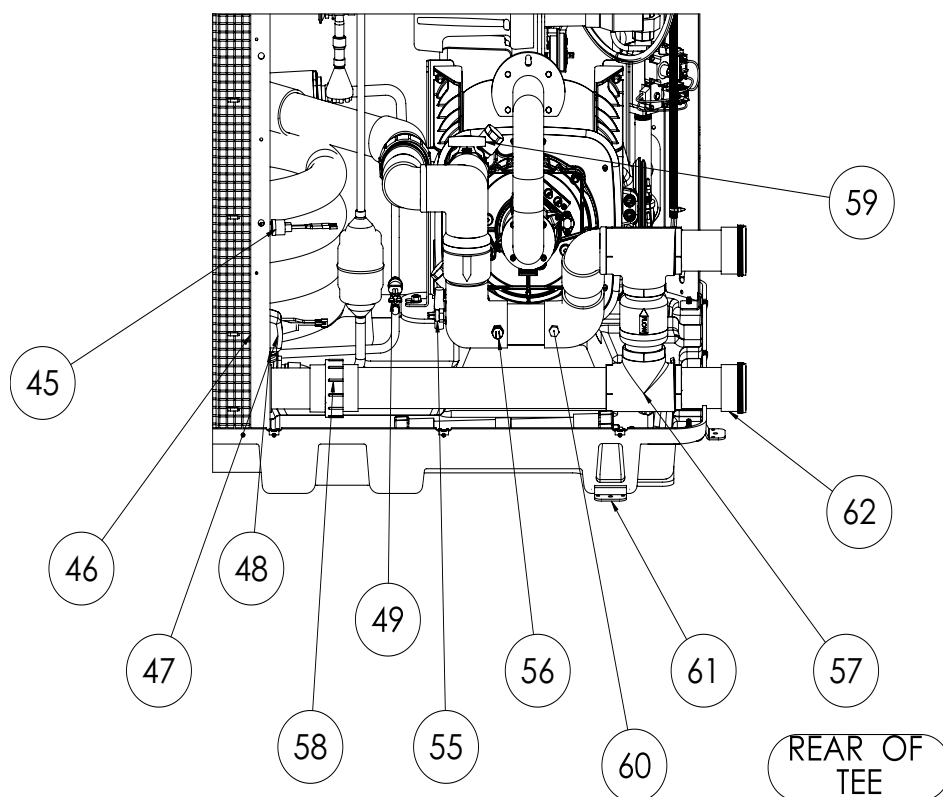

Item #	Part #	Description
45	473656	Switch, Low Refrigerant Pressure
46	473665	Probe Thermistor, Defrost Sensor
47	473606	Water Pressure Switch Boot
48	475956Z	Water Pressure Switch
49	473744	Switch, High Refrigerant Pressure
55	475941	Switch, Automatic Gas Shutoff, 140° F
56	475955Z	Switch, High Limit, 127° F
57	471566	Probe, Thermistor Water Temperature
58	473381	Union PVC 2in
59	475953Z	QRC Clip
60	98218900	Drain Plug (1/4 NPT)

Item #	Part #	Description
61	475950Z	Hurricane Tie Down Straps
62	476032Z	Water Management Assembly
-	470284	Nut, J Clip (Base)
-	470281	Nut, U Clip (Panels)
-	470159	Panel Screws, Phillips, Almond
-	470161	Lid Bracket Scews, Square Drive, Almond
-	476036Z	Union/Tie Down Kit (Includes 8X Item 61 and 2X Item 58)
-	475943	Pressure Relief Valve Kit

(-) Not Shown

SAVE THESE INSTRUCTIONS



1620 HAWKINS AVE., SANFORD, NC 27330 • (919) 566-8000
10951 WEST LOS ANGELES AVE., MOORPARK, CA 93021 • (805) 553-5000
WWW.PENTAIRPOOL.COM

All Pentair trademarks and logos are owned by Pentair or one of its global affiliates. IntelliFlo®, IntelliPro®, UltraTemp ETi™, TitanTough™, EasyTouch® and Eco Select® are trademarks and/or registered trademarks of Pentair Water Pool and Spa, Inc. and/or its affiliated companies in the United States and/or other countries. Unless expressly noted, names and brands of third parties that may be used in this document are not used to indicate an affiliation or endorsement between the owners of these names and brands and Pentair Water Pool and Spa, Inc. Those names and brands may be the trademarks or registered trademarks of those third parties. Because we are continuously improving our products and services, Pentair reserves the right to change specifications without prior notice. Pentair is an equal opportunity employer.

© 2018 Pentair Water Pool and Spa, Inc. All rights reserved. This document is subject to change without notice.



P/N 475922 REV. A 5/18/18