



Owner's Manual and Maintenance Procedures



1017 SW Berg Parkway
Canby, OR 97013
Phone: 503.266.2231
Toll Free: 800.824.4387(US)
www.srsmith.com

DECK PROFILE SHEET CONFIRMATION

Aquatic access lifts are application specific. A completed Deck Profile Sheet helps to ensure the lift purchased for the application will work in accordance to ADA guidelines. S.R. Smith reviews all submitted Deck Profile Sheets as a service to our customers, free of charge. Before installing the pool lift, the installer must review and confirm the information provided on the Deck Profile Sheet. If the description of the application does not match the installation site, a new Deck Profile Sheet must be completed and submitted to S.R. Smith.

NOTE: FAILURE TO COMPLETE AN ACCURATE DECK PROFILE SHEET MAY RESULT IN THE LIFT NOT MEETING ADA COMPLIANCE GUIDELINES.

To complete the Deck Profile Sheet online, visit www.srsmith.com/liftprofile, contact Customer Service at (800) 824-4387 or email sales@srsmith.com.

deck profile sheet*


pool lifts

*Deck profile form must accompany your pool lift order.


1. Preferred Lift: PAL Splash! aXis multiLift

2. Gutter Configuration:


Fully recessed gutter




Fully recessed gutter w/ parapet




Partially recessed gutter



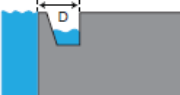
Above ground spa




Rollout gutter



Flush gutter and deck w/ or w/o bulinose



Standard backyard pool



Other: (please draw)

3. Deck Material (check one): Concrete Pavers

4. Distance from pool deck to water line (A):

If applicable:

5. Height of curb (B):

6. Width of curb (C):

7. Width of gutter (D):


8. Decorative stone setback:

Note: As pools may vary, please insert accurate measurements for your pool in the space provided. Manufacturer will configure the lift to match your unique poolside specifications. Order cannot be processed without the required fields entered above.

Fax this completed form to 503.266.4334 or email to sales@srsmith.com

<input type="text" value="Name of Distributor Lift Will Be Purchased From"/>	<input type="text" value="City"/>	<input type="text" value="State"/>
<input type="text" value="Your Name"/>	<input type="text" value="Email"/>	<input type="text" value="Phone"/>
<input type="text" value="Project Name"/>	<input type="text" value="PO Number"/>	

toll free 800.824.4387
fax 503.266.4334
web www.poollifts.com



SF-720-003
10/2011

TABLE OF CONTENTS

PAL²

202-0000

INTRODUCTION	4
USING THE PAL ² LIFT	4
WARNINGS AND SAFETY SUMMARY	5
PRODUCT OVERVIEW	7
PAL ² – Portable Aquatic Lift - PRODUCT COMPONENTS	7
UNPACKING & ASSEMBLY INSTRUCTIONS	12
USING THE PAL ² – Portable Aquatic Lift	18
POSITIONING	19
TRANSFERRING	19
STANDARD ACCESSORIES/OPTIONAL ACCESSORIES	20
MAINTENANCE and CLEANSING.....	21
TROUBLE SHOOTING	22
LONG-TERM STORAGE	23
WARRANTY INFORMATION	23
SPECIFICATIONS	24
2. Actuator	25
3. Motor	25
4. Battery	25
5. Range of Motion	25
6. Noise	25
7. Materials and Finish.....	25

READ THESE INSTRUCTIONS IN THEIR ENTIRETY BEFORE BEGINNING INSTALLATION

INTRODUCTION

The purpose of this document is to provide information relating to the safe operation, care, and maintenance of the **PAL² (202-0000)**

Read and Follow all User Instructions listed in the Owner's Manual before use
Read and Follow all Caution and Warning labels located on the lift before use

INTENDED LIFT USER

All of S.R. Smith's lifts have been designed to assist anyone who has problems entering or exiting a swimming pool or spa - the only restriction is that the User does not exceed the weight limit of the product (300 lb/136 kg). It is the responsibility of the lift Owner to ensure that the correct safety procedures have been put in place and a risk assessment carried out. The unit must be correctly positioned with the stabilizer arms fully extended and the rear brakes fully applied prior to use. If a User is mentally challenged or has severe physical disabilities these issues must be taken into account to determine the number of persons required to complete the transfer onto the seat and the number of persons required to be in the water, ready to receive the User. The correct stabilizing system (seat belt or stability vest) must be attached to the seat and fully fastened and used during each transfer.

Our goal is to provide our customers with the most advanced and innovative designs offering exceptional quality at affordable prices. All of our lifts meet the specifications set forth by the Access Board - ADAAG 2004 (US only), Medical Device Directive, and ISO10535:2006 including repeating the lifting cycle of the hoist (lift) for a total of 11,000 cycles. The lift system and AC powered battery charger complies with EN60601-1-2, 2007/03.

USING THE PAL² LIFT

Obey all User Instructions listed in the Owner's Manual whenever using lift. Obey all Caution, Warning, Operating Instruction(s) and Labels located on the lift whenever using. It is the responsibility of the lift Owner to ensure that the correct safety procedures have been put in place and a risk assessment carried out. If a User is mentally challenged or has physical disabilities these issues must be taken into account to determine the number of persons required to complete the transfer onto the seat and the number of persons required to be in the water, ready to receive the User. If the PAL² will be used by a disabled person living on their own, a communication device should be installed in the area of use to call for assistance in the event of an emergency. Only persons healthy enough for water activities should use the PAL². Users should consult with their physician to determine if water activities are appropriate for the User. Keep fingers and hands clear of lift arms during use.

US Patent No. 5,790,995

PAL² - Portable Aquatic Lift, the PAL2 logo and LiftOperator are trademarks of S.R. Smith, LLC

WARNINGS AND SAFETY SUMMARY



DANGER – FAILURE TO FOLLOW THESE WARNINGS, INSTRUCTIONS AND THE OWNER’S MANUAL MAY RESULT IN SERIOUS INJURY OR DEATH

WARNING

- **ADULT USE ONLY** – Use by children with adult supervision only. Only persons healthy enough for water activities should use the aXs. Users should consult with their physician to determine if water activities are appropriate for the User.
- Seat belt is to be used at all times during user transfer.
- **NO JUMPING/DIVING/CLIMBING** – Do not jump/dive from or climb on lift.
- Limit for use is **ONE PERSON** weighing less than the maximum weight limit of – 300lbs (136kg) for the aXs. Use only for transfer of user not as a hoist or crane.
- **PINCH/CRUSH HAZARD** – Always keep hands and fingers clear of lift arms during use.

CAUTION

- **BATTERY CHARGE LEVEL** – Check Battery Level before each use. Battery must show **GREEN** >50% charge level before use. When **YELLOW** <50% charge level is shown the battery must be fully charged before use. When **RED** <25% charge level is shown the lift must not be used and the battery must be fully charged before use.
- **DAMAGE MAY RESULT** – Do not use the seat or seat frame to move or position the aXs.
- **DAMAGE MAY RESULT** - Do not allow excessive moisture to collect in the battery case, it can affect battery and lift performance and could lead to battery failure and/or the lift failing to operate.

Model / Product No. _____
Product Name _____



S.R. Smith, LLC
 PO Box 400
 1017 SW Berg Parkway
 Canby, Oregon 97013 USA
 Phone: 503-266-2231
 Fax: 503-266-4334
 www.srsmith.com
 Assembled in USA

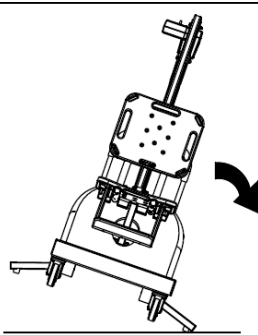
SN S

EC REP

QNET B.V.
 Hommerweg 286
 6436 AM Amstenrade
 The Netherlands
 qnet@ce-mark.com
 qnet@ce-authorizedrepresentative.eu

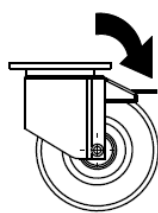


24 VDC



WARNING **TIPPING HAZARDS**

- STABILIZING ARMS MUST BE FULLY EXTENDED BEFORE EACH USE AND MUST BE USED AT ALL TIMES WHEN A USER IS SEATED.
- THE LIFT MAY NOT BE USED WITHOUT THE STABILIZING ARMS FULLY EXTENDED.
- NEVER ATTEMPT TO RETRACT THE STABILIZING ARMS WHEN THE LIFT IS IN USE.
- DO NOT REPOSITION THE LIFT WHEN THE LIFT IS IN USE.
- USE ON A FIRM LEVEL SURFACE NOT TO EXCEED A 2° SLOPE.
- ENSURE PROPER BALAST WEIGHTS ARE INSTALLED IN LIFT BASE BEFORE EACH USE.
- DO NOT USE THE LIFT TO TRANSPORT USERS FROM PLACE TO PLACE.
- LIMIT FOR USE IS ONE PERSON WEIGHING LESS THAN THE MAXIMUM WEIGHT LIMIT OF 300 LB (136 kg).



WARNING

- **REAR WHEELS MUST BE LOCKED AT ALLTIMES WHILE THE LIFT IS IN USE.**
- **FAILURE TO LOCK WHEELS MAY RESULT IN UNINTENDED MOTION OR TIPPING.**

WARNING

TIPPING HAZARD

LIMIT FOR USE IS ONE PERSON WEIGHING LESS THAN THE MAXIMUM WEIGHT LIMIT OF 300 lbs (136 kg)



WARNING

Pinch Points.
 Moving part can crush or cut.
KEEP CLEAR.

ADA GUIDELINE SUMMARY* (USA Only)

1009.2.1 Pool Lift Location

Pool lift shall be located where the water level does not exceed 48". If entire pool water level exceeds 48", place pool lift where convenient.

1009.2.2 Seat Location

In the raised position, the centerline of the seat shall be located over the deck a minimum of 16" from the edge of the pool.

1009.2.3 Clear Deck Space

On the side of the seat opposite the water; a clear deck space shall be provided parallel with the seat. The space shall be 36" wide minimum and shall extend forward 48" minimum from a line located 12" behind the rear edge of the seat.

1009.2.4 Seat Height

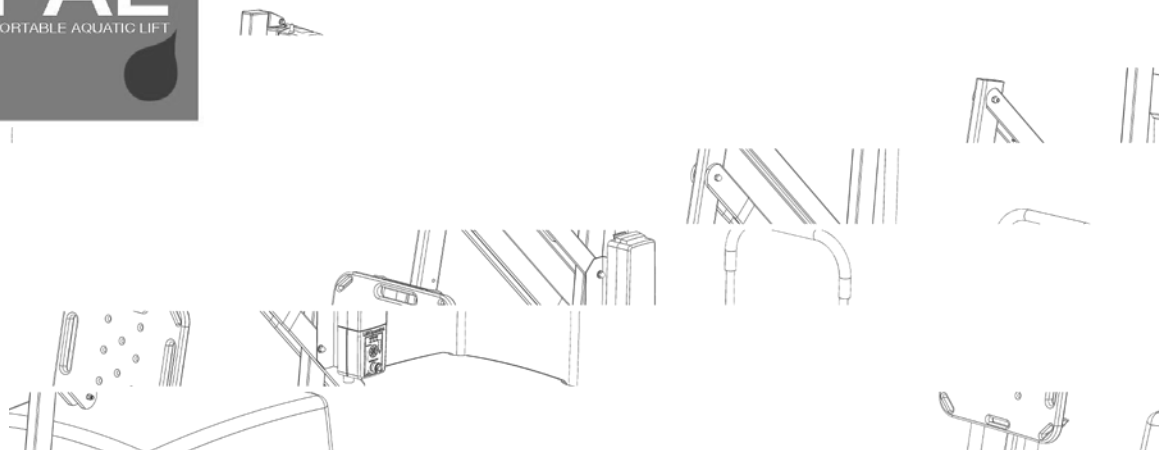
The lift shall stop at 16" – 19" measured from the deck to the top of the seat surface when in the loading position.

1009.2.8 Submerged Depth

The lift shall submerge the seat a minimum of 18" below the stationary water level.

*Compliance with ADA is the responsibility of the pool owner. Visit www.ada.gov for complete guidelines.

THE PAL² - PORTABLE AQUATIC LIFT

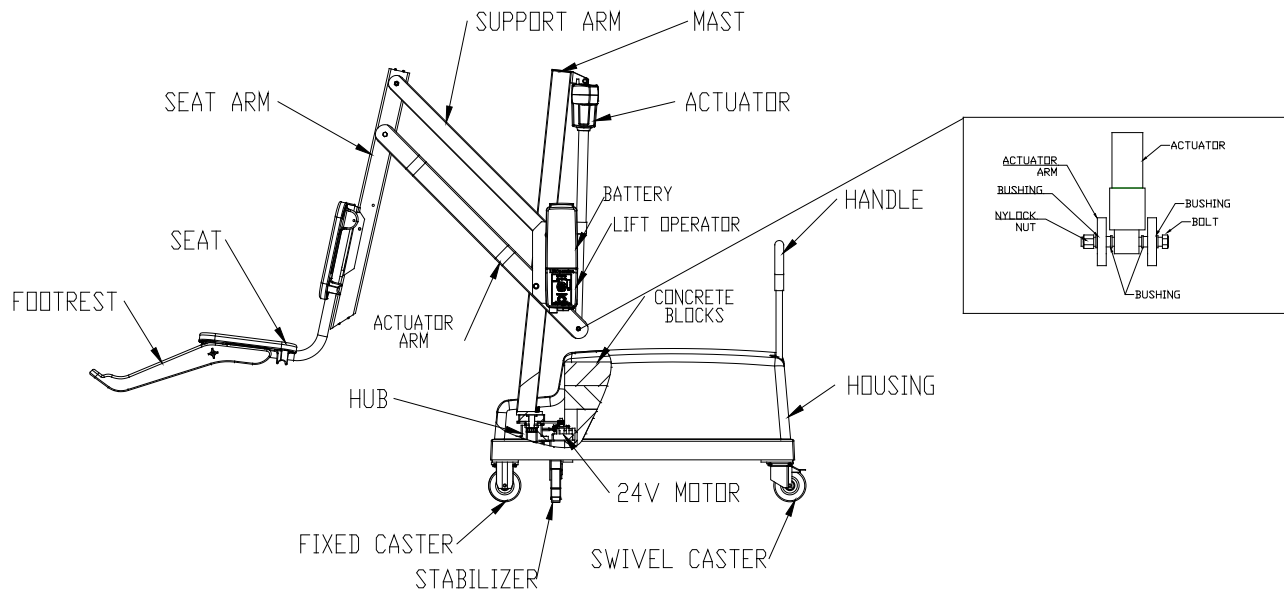


PRODUCT OVERVIEW

The PAL²-Portable Aquatic Lift is a portable lift system designed so that individuals with disabilities and mobility impairments can have universal access to any type of swimming pool. The PAL² is powered by a 24 volt rechargeable battery operated by a screw-driven electronic actuator that provides the lifting and turning motions. S.R. Smith has designed the safest possible lift system, following all instructions in the owner's manual, and all product labels is necessary to achieve safe, reliable and proper performance of the lift and avoid injury. This design ensures consistent safe operation and minimizes service problems. The PAL² is designed to provide flexibility for aquatic facilities seeking to provide access to more than one pool, or to accommodate a user's desire to enter a single pool in multiple locations. The maximum lift capacity for all PAL² models is 300 lb/136 kg. The PAL² lift shall be used on rigid level pool deck surfaces not to exceed a slope of 2°. Only persons healthy enough for water activities should use the PAL². Users should consult with their physician to determine if water activities are appropriate for the User.

WARNING: The PAL² lift is designed to transfer (lift) users from the deck surrounding the swimming pool into the water and back again. It is not designed to transport users from place to place. Serious injury can result if the lift is moved while a user is in the seat.

PAL² – Portable Aquatic Lift - PRODUCT COMPONENTS



COMPONENT DESCRIPTION

The Base Assembly is made up of several components as described below:

Wheels- Front wheels are rigid and back wheels swivel to facilitate movement. Both back wheels can and must be locked to prevent movement during transfer to and from the pool.

WARNING: Failure to lock both rear wheels during transfer could cause lift movement and may result in injury. Both rear wheels must be locked whenever the lift is positioned for use. Do not unlock rear wheels during transfer as the lift could move and may result in injury.

Main Frame - The rectangular piece that is fixed to the wheels - the main frame is made up of several components:

Stabilizing Arms - Two arms pull out to level the lift and must always be fully extended when the lift is in use.

WARNING: Failure to fully extend both stabilizer arms during transfer could cause lift movement and may result in injury. Both stabilizing arms must be fully extended whenever the lift is positioned for use. Do not retract stabilizing arms during transfer as the lift could move and may result in injury.

Housing - ABS plastic cover shields main frame components from weather. The housing needs to be in place prior to installing mast assembly.

Handle - Connects to Main Frame through openings in housing.

Lift Operator - The LiftOperator is available with an optional Activation Key feature that provides a higher level of security by allowing control operation only with the use of the activation key. The unit controls all lift operations identical to the user hand set. Three cables connect to the bottom of the Control Box to enable operation of the lift. The largest connector is for the hand control. Connector # 1 is for the motor cable (red stripe). Connector # 2 is for the actuator cable (green stripe).



Touchpad Control –

The touchpad control arrow keys can be used in the event that the hand control is out of reach or fails. Simply press and hold the arrow for the desired action for one movement at a time – Up, Down, Left, Right. Releasing the Arrow stops movement.

Battery Level LED Indicators –

The Battery Level LED Indicators show battery charge levels. The LED's will illuminate when either the touchpad control or the hand control is activated and will stay lit for 10 seconds. At greater than 50% the LED glows Green, at less than 50% the LED glows Amber, and less than 25% the LED glows red and indicates the battery requires charging. If the less than 25% LED glows red, do not operate the lift. Remove the battery and fully charge before use.

Service Required LED –

The Service Required LED will illuminate when the battery pack has been removed/replaced 120 times - approximately once every 4 months. This indicates that required maintenance for the lift must be completed. Please see the maintenance section of the Lift Owner's Manual for the requirements. The Service Required LED can be reset by inserting a standard FAT-formatted USB mass storage device (not included) into the USB Port on the bottom of the controller. **When the service light is illuminated the lift must not be used until required maintenance is performed.**

Emergency Stop Button –

In the event of an emergency, or if you need to stop lift movement immediately, pressing the Emergency Stop Button (red button on the control) will stop all lift movement. At the same time an audible alert will sound for 10 sec. then pause for 5 sec. and then the sequence will repeat until the button is reset by turning it in the direction of the arrows on the button (clockwise). The Emergency Alert LED will also flash Red when the button is pressed and will remain flashing until the button is reset.

The Emergency Alert (audible and LED) can be activated by pressing any two buttons on the hand control at the same time (provided with the lift). This will stop all lift movement and activate the audible alert and the Red LED will flash. Once both buttons are released, the lift will return to normal operation and the emergency audible alert will silence.

Activation Key –

The Optional Activation Key provides a higher level of security by allowing control operation only with the use of the optional activation key. To enable operation slide the Access Key into the slot next to the touchpad control arrows. To disable operation remove the key. When the key is inserted or removed the Battery Level LED will illuminate for 10 seconds.



Activation Key (Option)

USB Port –

The LiftOperator control contains a USB port that is used to download the performance log of the lift. Using any standard FAT file formatted USB memory stick (widely available through retail outlets) insert the stick into the slot on the bottom of the control on the far right hand side. Press any of the touchpad control arrows; all three of the Battery Level LED's will flash. During downloading the Green greater than 50% Battery Level LED will flash. If the unit has a problem downloading the performance log the Red less than 25% LED will flash. Remove the USB from the port and re-insert it. If the Red 25% LED flashes again, confirm that the USB you are using is FAT file formatted. The information from the USB can be downloaded to a PC for review and/or copied to a spread sheet. The performance log will retain approximately 7,600 events. Once the file is full it will remove the oldest event and replace with the newest.

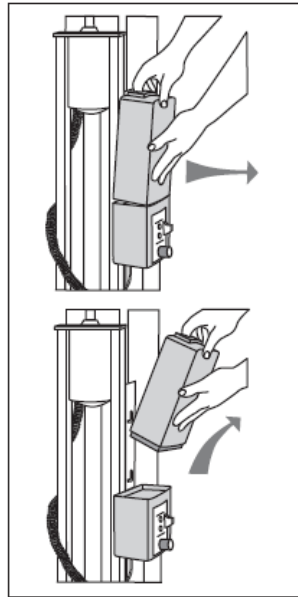
After the summary data, the events are shown with the oldest first. The first column is the time in seconds from that last event. The second column is the text describing the event. The third column is duration of the activity noted in seconds.

An example of a short log file:

<u>Activity</u>	<u>Description</u>
dev_id_upper,0	Programing data
dev_id_lower,1	Programing data
fw_rev,90	Firmware rev.
batt_volt_float,24929	Non-loaded battery voltage in millivolts
batt_volt_load,21487	Loaded battery voltage in millivolts
batt_capacity,99	Estimated battery capacity in %
charge_starts,8	Number of times charging was attempted
charge_completes,1	Number of times charging was finished successfully
0,power_on,1	Connecting Battery Pack
0,key_enable,	Inserting Activation Key
2,alert_pressed,	Emergency Button pressed
3,alert_released,	Emergency Button released

8, lift_up, 2	Lift movement - up
5, lift_down, 2	Lift movement - down
11, lift_up, 2	
4, turn_left, 2	Lift movement - turn left
3, turn_right, 1	Lift movement - turn right
308, key_disable,	Removing Activation Key
3, log_write,	USB File Download

Battery Pack - The battery pack is located on top of the Control Box and is removable.



To remove - pull the battery pack away from the mounting plate so that the latch on the battery pack clears the side tabs on the mounting plate - then lift the battery pack up and away from the Control Box.

To replace - align the battery pack with the mounting plate so that the latch will drop over the center tab and that the bottom of the battery pack will fit in the recessed area on top of the Control Box. Lower the battery pack in place so that the latch is fully captured by the mounting plate and the battery pack drops fully seated onto the Control Box.

The battery must be completely removed from the lift and located away from the pool deck for charging.

The battery pack should be charged daily. Do not allow battery to fully discharge, as it will shorten battery life.

The battery pack has an LED indicator near the plug-in-port. It will glow Red when first plugged into the transformer. If the LED remains Red this indicates the battery pack needs charging. When fully charged the LED will glow Green. If the battery is fully charged and is plugged into the transformer the LED will glow Red for approximately 10 sec. then glow Green. If the LED flashes Red when plugged in this indicates a fault with the battery and indicates the battery pack should be replaced. All batteries are inspected prior to shipment. See warranty policy regarding battery replacement for problems after sale. Batteries have a normal lifespan of between 2-3 years, depending on use and care. A



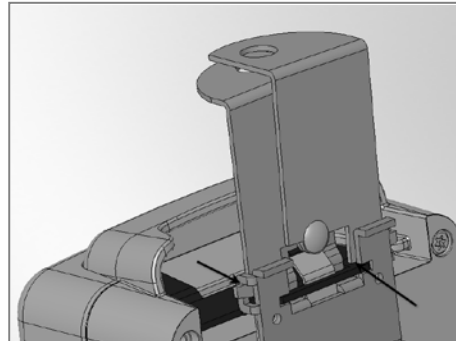
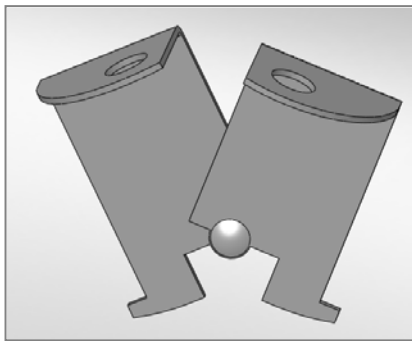
fully charged battery will provide approximately 30 to 40-lifting cycles, depending on the weight of the users. Prior to use the battery charge level should be checked by observing the LED indicator above the charger plug to ensure sufficient charge level. The charger must be connected to the battery to view the LED.

It is not necessary to fully discharge the battery prior to charging. Battery should be charged daily and cannot be overcharged. It takes up to six hours to fully charge depending upon battery usage. Do not allow battery to fully discharge, as it will shorten battery life.

Do not drop the battery, as it could cause the unit to fail. If the battery case is cracked do not use and replace the battery. During temperature extremes beyond the range of 41 F (5 C) to 104 F (40 C) remove battery and place in a controlled environment or battery life may be shortened.

Battery Disposal - The batteries located inside the battery pack are recyclable and shall be disposed of in accordance with applicable local, state/provincial or federal/national regulations.

Locking Plate Assembly - The battery pack can be secured to the mounting plate using the provided lock plate assembly. To install open the lock plate so that the bottom tabs are moved close to one another to allow the lock plate to be inserted into the slots on the mounting plate secured to the lift. Close the lock plate assembly so that the tabs are captured by the slots. Insert a padlock (not provided) through the holes on the lock plate assembly to secure it.



Hand Control - The four button unit controls all lift movements. The arrows indicate direction of movement. Control is fully waterproof and meets IP67 standards.

Mast - This vertical piece is bolted to the base assembly.

Actuator - Attached to mast, this part powers the up and down movements of the lift.

Rotation Motor Assembly - Consists of mounting plate, 24-volt motor, and small gear.

Hub Assembly - Consists of hub, bearings, shaft, large gear and mast mounting plate.

Horizontal Support Arms - These two support arms connect the mast to the seat support arm. The longer horizontal support arm (actuator arm) connects to the actuator and initiates lifting movements.

Seat Arm - Connects the seat to the horizontal support arms.

Seating System - The seat is manufactured from roto-molded plastic with a stainless steel frame. There are two available forms of safety devices - the standard seat belt and optional stability vest. The seat has



4 Button Hand Control

attachment points for both devices and both are easy to attach. Be sure to select the appropriate safety device for the intended User.

- It is recommended that people with limited or no body movement at or below the waist shall use the seat belt restraint when using the lift.
- It is recommended that people with limited or no body movement at or below the shoulders shall use the optional stability vest restraint when using the lift.

The seat belt or optional stability vest must be used during each use. The footrest is removable and will float upwards to prevent damage if the seat is lowered too far. It is recommended that the seat be rinsed off with fresh water between each use and cleansed daily with a disinfectant solution of 1:100 dilution of household bleach to fresh water and then rinsed with fresh water. In the event of a contamination incident such as patient/user excreta - cleanse seat and seatbelt or stability vest immediately with the above disinfectant solution. Do not use the seat or seatbelt or stability vest if it is damaged or becomes worn out.

The optional armrests (US only - standard on export models) are designed for support when transferring onto the seat. They can be rotated up out of the way during transfer. If the lift did not include the optional arm rests (US only) they can be purchased separately and easily installed at a later date.

This lift seat assembly is designed to be used exclusively with S.R. Smith aquatic access lifts.

UNPACKING & ASSEMBLY INSTRUCTIONS

REFER TO DIAGRAM (page 5) FOR PARTS IDENTIFICATION.

READ THESE INSTRUCTIONS IN THEIR ENTIRETY BEFORE UNCRATING PAL²

Prior to opening pallet, inspect external condition for any visible damage. It is important that any damage be noted on the Bill of Lading. Immediately notify S.R. Smith or your Authorized Reseller of missing or damaged parts.

The PAL² is shipped on a covered pallet and is **VERY HEAVY**. You will need the following tools for unpacking and assembly:

- 3/4" or 19mm socket wrench
- 9/16" or 14mm socket and 9/16" or 14mm wrench
- small flat blade screwdriver
- knife or cutters to cut shrink-wrap/bands
- claw hammer

Unpacking & Assembly Procedure for the PAL² – Portable Aquatic Lift²

1. Cut open enclosure bag at base of unit - carefully remove plastic.
2. Cut internal bands – remove mast assembly, seat assembly and housing. Lift assembly by mast and seat arm. ***Do not lift mast assembly by actuator as this could damage the actuator.***
3. Remove accessory box.
4. Remove the PAL² handle from the frame.
5. Roll the main frame from the pallet, across the top of the concrete weights. Position main frame close to pallet and lock both rear casters.
6. **Counter Weights and Weight restraint belts.**

The concrete weights for the lift are located in the bottom of the pallet. Using the claw hammer, remove the wood restraints to gain access to the blocks. In the accessory carton are the two black belts used for restraining the weights. Follow the images below to properly install the belts and concrete blocks.

Each concrete weight is approximately 33 lbs /13.6 kg.

Weights leave the factory in good condition; however, they may have shifted during shipping. Inspect the weights prior to installation to be sure there are no cracked or broken blocks. **DO NOT USE DAMAGED WEIGHTS.** Contact S.R. Smith at (800) 824-4387 for replacement.

Use caution when lifting the weights, until they are in their final position, mishandling can crack or break the weight.



IMAGE 1



IMAGE 2

Lace the belts through the frame, as shown in **image 1**. Place the outer most blocks in position, as shown in **image 2** and pull the slack out of the restraint belts.

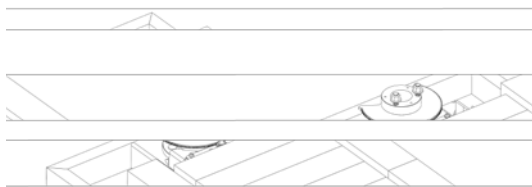


IMAGE 3

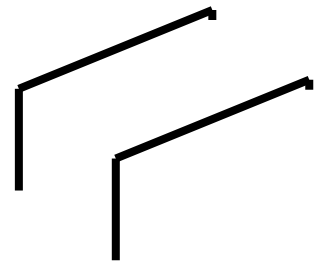


IMAGE 4

Image 3 shows the first layer of concrete weights installed. **Image 4** shows how to properly stack the last two layers of concrete weights, using all 24 blocks. Close all gaps between the top layers, ensure they are all touching and pressed firmly together before tightening the weight straps.



IMAGE 5

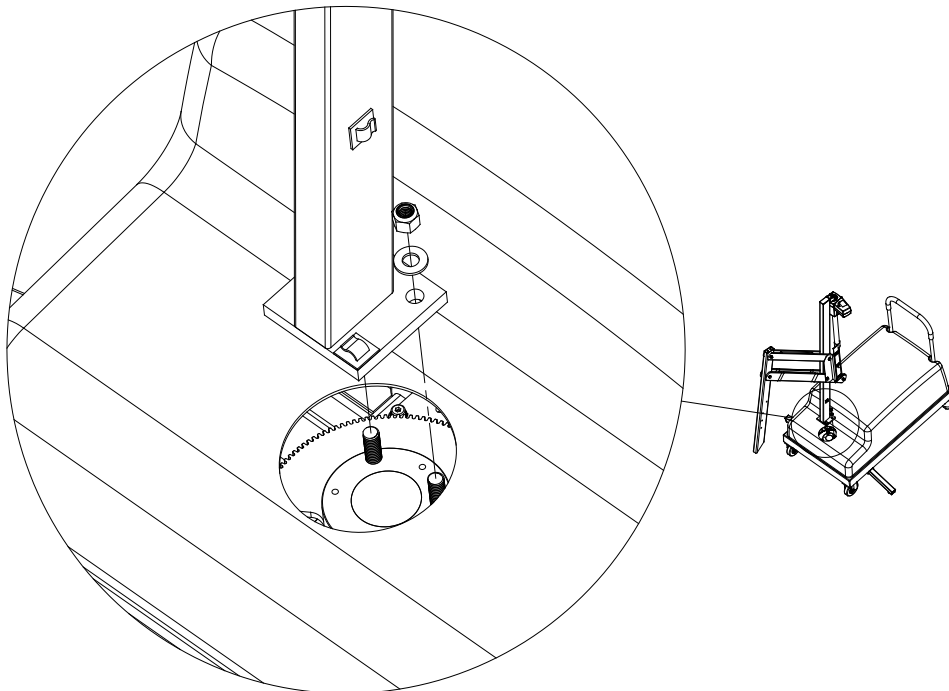
Tighten both straps as shown in Image 5 across the top of both rows of weights. Loop the strap through its buckle and pull firmly securing each top row of weights.

CAUTION: The restraining harnesses must be correctly installed. Failure to correctly attach the restraining harness to frame may result in the weights shifting during use.

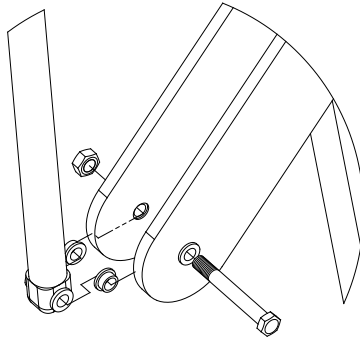
7. Place housing on frame. Ensure the housing fits square and flush to the frame. If necessary, re-adjust the concrete blocks to address any interference with the housing cover.

8. Remove the two lock nuts and washers from mast mounting hub on base assembly (as shown below).

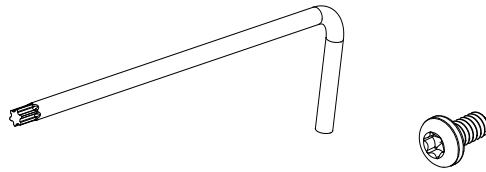
9. Position mast assembly through housing and attach to studs located on base assembly with lock nuts and washers. Fully tighten with 3/4" or 19mm socket wrench.



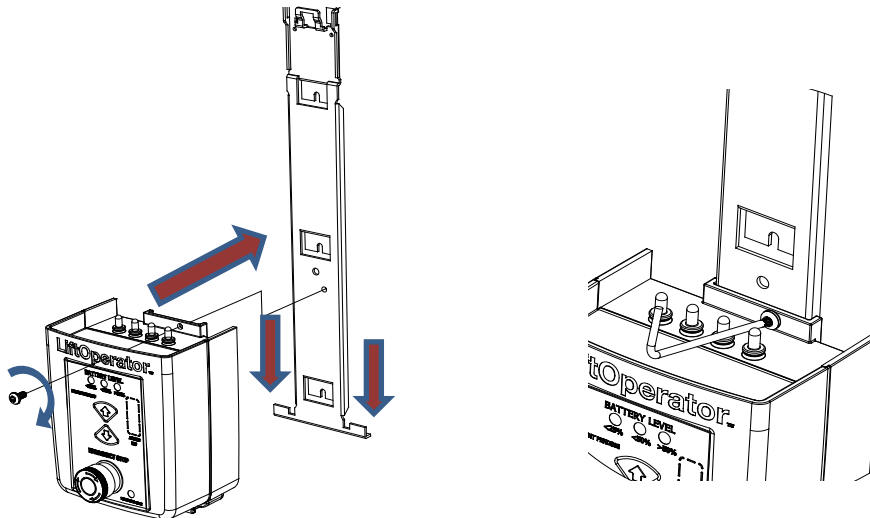
10. Remove plastic from the mast assembly. Remove 3/8"(10mm) bolt and nut from the end of the actuator arm. Following the illustration below, attach actuator end to end of actuator arm using the 3/8"(10mm) bolt and nut. Fully tighten bolt and nut using 9/16"(14mm) socket and wrench.



11. The accessory carton contains the control box. Remove the control box and separate the T-20 Star wrench and the small torx screw from the control box.

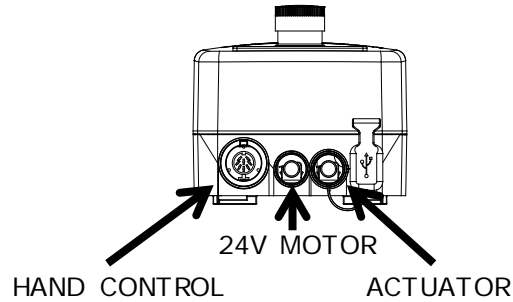


12. Attach the control as illustrated below.



13. Remove the battery from the accessory carton and carefully attach to controller as shown on page 10.

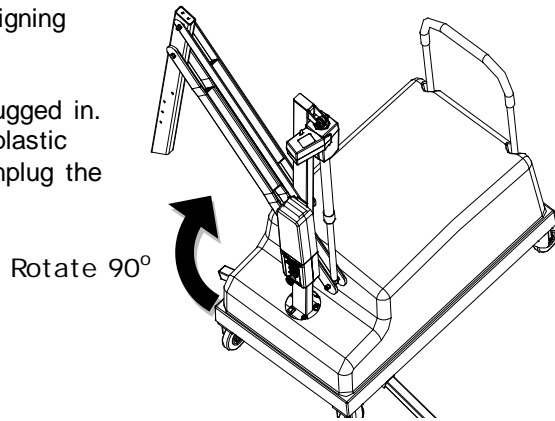
14. Insert actuator cable (green label) into connector #2 on the Control Box. Make sure the plug is secure and fully seated.



15. The 24V motor cable will be secured to the mast in **step 18**. For the moment, simply string it through the housing mast hole. Plug the 24v motor cable (red stripe) into connector #1 on the Control Box. Make sure the plug is secure and completely seated. Allow the 24V motor cable to hang freely and untangled from the first clip pre-installed. keep it out of the gear.

16. Remove the hand control from the accessory carton. Insert plug into large connector on the Control Box aligning the key way of the plug.

17. With the battery connected and the 24V Motor plugged in. Rotate the lift using the right arrow so that the white plastic wire clips attached to the **mast** face forward. Next, unplug the 24V motor cord from the controller.



18. To secure the motor cord, follow the steps in the figures below -

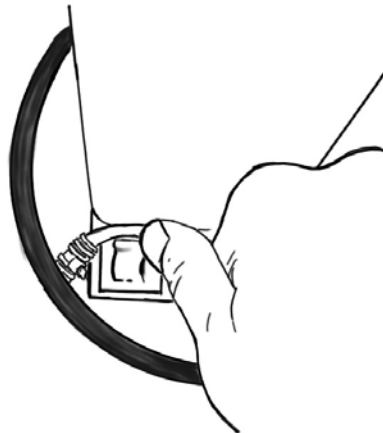


Figure 1: Clip the wire into the lower mast clip

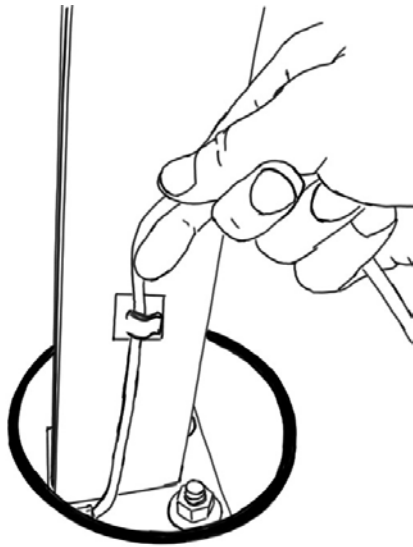


Figure 2: Lightly tension the wire and clip it into the higher mast clip.

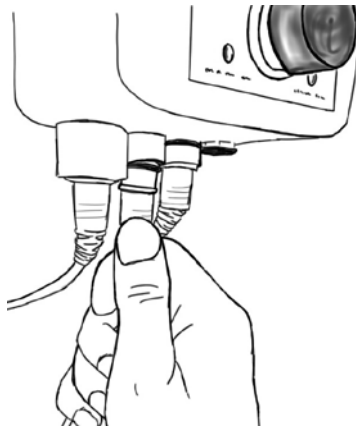


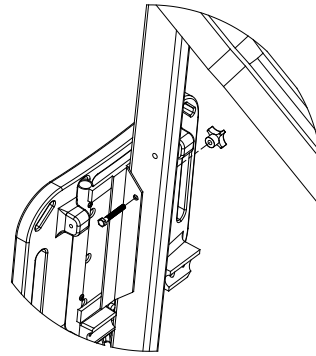
Figure 3: Make sure there are no tangles. Then plug the 24V Motor into place.

19. Figure 4 illustrates the correct attachment of the motor cable under the housing cover. Rotate the lift back and forth while observing the cable to ensure the cable does not become entangled in the gear assembly.

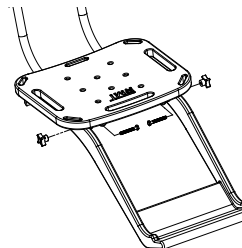


Figure 4: The cable, as it should appear to be under the Housing cover.

20. Check up and down controls for proper operation - both touch pad and hand controls.
 21. Check Emergency Stop button for operation/activation of internal sounder.
 22. For Controls with the optional Activation Key – the key must be inserted into slot for operation. When key is removed lift will not operate. (Note – Emergency Stop button and alert will operate without key inserted into slot)
- 23. Remove the battery and charge it fully before users begin to use the lift.**
24. Fully extend both stabilizer bars and fully lock both rear wheels to prevent movement.
 25. Attach seat assembly with bolt and thumbnut in appropriate hole. For storage, seat can be attached facing inward for less space.



26. Attach foot rest to seat with bolts and thumbnuts.



USING THE PAL² – Portable Aquatic Lift

Obey all User Instructions listed in the Owner's Manual whenever using lift. Obey all Caution, Warning, Operating Instruction(s) and Labels located on the lift whenever using. It is the responsibility of the lift Owner to ensure that the correct safety procedures have been put in place and a risk assessment carried out. If a User is mentally challenged or has severe physical disabilities these issues must be taken into account to determine the number of persons required to complete the transfer onto the seat and the number of persons required to be in the water, ready to receive the User. If the PAL² will be used by a disabled person living on their own, a communication device should be installed in the area of use to call for assistance in the event of an emergency. Only persons healthy enough for water activities should use the PAL². Users should consult with their physician to determine if water activities are appropriate for the User. Keep fingers and hands clear of lift arms during use.

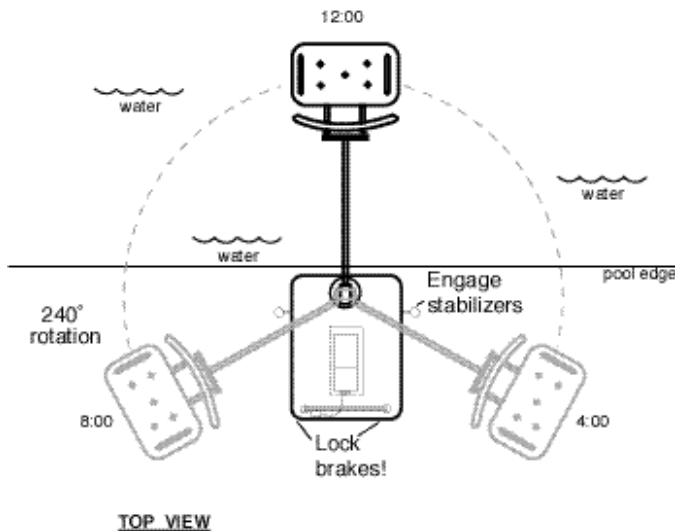
POSITIONING

Four important things to REMEMBER when positioning the PAL² for use:

1. Maintain a firm grip on the handle - use care when positioning the PAL². It is heavy (1000 lb/ 453 kg) Do not use the seat as a hand hold to move the PAL² – Only the handle should be used to position the lift.
2. Position the PAL² on level ground not to exceed a slope of 2° and in an area that allows for safe transfer to and from a wheelchair. Consult the ADA guidelines on page 6 for more detailed information.
3. Fully extend both stabilizing arms.
4. Lock both rear wheels.

WARNING: Failure to fully extend both stabilizing arms and to lock both rear wheels could cause lift movement during transfer and could result in injury. Both stabilizing arms must be fully extended and both rear wheels must be locked whenever lift is used. Do not retract stabilizing arms or unlock rear wheels during transfer as the lift could move and may result in injury. The maximum lift capacity is 300 lb/136 kg. Keep fingers clear of lift arms during use.

PAL² Positioning Diagram



TRANSFERRING

Once the unit is positioned for use with both **stabilizing arms fully extended and both rear wheels locked** - use the following procedure to transfer to the seat and into the water. Only persons healthy enough for water activities should use the PAL². Users should consult with their physician to determine if water activities are appropriate for the User:

- Keep fingers and hands clear of lift arms during use.
- Rotate seat to either side of the lift for the ideal transfer position.

- Raise or lower seat to ideal transfer height.
- Transfer onto seat, ensuring user's weight is centered on seat. Armrests can be rotated up if necessary (optional US/standard on export). If user has a wheelchair, keep chair close by for easy retrieval.
- Fasten Seat Belt - thread loose end of belt strap through buckle - pull tight - to close - press latch down on belt material.
- Or fasten optional Stability Vest - Position shoulder straps onto shoulders and attach straps to clips on bottom panel of the Stability Vest - pull shoulder straps tight.
- Raise seat to allow enough legroom for rotation.
- Rotate seat to the 12 o'clock position, over water.
- Lower seat into pool. The waterproof hand control can remain connected to seat if swimmer is operating lift.
- Unfasten Seat Belt - grasp latch and lift up, pull loose end from latch.
- Or unfasten optional Stability Vest - unclip shoulder straps and transfer into water.
- When finished, return to seat, ensuring user's weight is centered on seat.
- Raise seat to allow enough legroom for rotation.
- Rotate seat to original transfer position.
- Raise or lower seat to proper transfer height.
- Unfasten Seat Belt or optional Stability Vest.
- Transfer off of seat.

WARNING: The PAL² lift is designed to transfer users from the deck surrounding the swimming pool/spa into the water and back again. It is not designed to transport users from place to place. Serious injury can result if the lift is moved while a user is in the seat.

IN CASE OF HAND CONTROL FAILURE

Lifting failure - In the event of a lifting failure, there are control buttons built into the control box. Press the appropriate up or down/ left or right button located on the front panel of the control box.

If the PAL² will be used by a disabled person living on their own, a communication device should be installed in the area of use to call for assistance in the event of an emergency.

IN CASE OF BATTERY FAILURE

Turning failure - If the lift will not turn electronically, you can remove the housing and loosen the nut (7/16" – 11mm) on the tension spring located next to the turning motor. This will disengage the gears and allow the lift to be turned manually.

If the PAL² will be used by a disabled person living on their own, a communication device should be installed in the area of use to call for assistance in the event of an emergency.

STANDARD ACCESSORIES/OPTIONAL ACCESSORIES

The following items are included with all pool lift models:

- Seat Belt Assembly - Nylon water-resistant belt for added security.
- Battery/Charger – 24-volt rechargeable battery.

Optional accessories may be purchased for your PAL² - Portable Aquatic Lift² through your Authorized Reseller. The following accessories are available:

Stability Vest - P/N 900-2000: Five point restraint for individuals who need higher degree of stability than provided with standard seat belt.

Deck Cover PAL /SPLASH - P/N 920-5000: Made of weather resistant nylon material to keep unit protected from elements when not in use.

Arm Rest Assembly - P/N 170-1000: Powder coated stainless steel arm rests for increased sense of security.

Spine Board Attachment - P/N 500-1000: Can be used to convert lift for use with any standard spine board. (Spine Board not included)

Seat Pad - P/N 890-1000: Waterproof seat pad designed to enhance comfort during transfer.

Console/Battery Cover – P/N 910-1000: Protects battery and control unit from exposure to UV and moisture.

MAINTENANCE and CLEANSING

Minimal maintenance will prolong the life of your lift. Keep all electronic components clean and dry. Keep the Console/Battery Cover installed at all times to prevent moisture from collecting on the Control Box and battery. Excessive moisture collection can affect battery and lift performance and could lead to battery failure and/or the lift failing to operate. If the lift is used outdoors, an optional full cover is available and recommended.

Owners of lifts shall be aware of any applicable local, state/provincial or federal/national regulations regarding the inspection and or testing of lifts.

The following schedule must be performed to insure proper operation with the Daily items performed before each use:

Maintenance Performed	Daily	Weekly	Monthly
Check battery level before each use / Charge battery daily	✓		
Wipe Control Box and battery connection with a clean dry rag	✓		
Examine lift for any damage, loose or missing hardware	✓		
Test for normal operation	✓		
Spray gear assembly with a heavy-duty rust inhibitor/lubricant such as LPS 3 - Heavy-Duty Inhibitor		✓	
Make sure all cable connections are properly secured			✓
Inspect lift frame, mast, support arm and seat assembly for rust			✓
Inspect weight stack for rust/treat with touch up paint			✓
Cleansing Performed – after each use			
Rinse seat and seatbelt/stability vest with fresh water between each use - Cleanse seat and seatbelt/stability vest with a disinfectant solution of 1:100 dilution of household bleach to fresh water and then rinse with fresh water and dry entire lift daily. In the event of a contamination incident such patient/user excreta - cleanse seat and seatbelt/stability vest immediately with the disinfectant solution*	✓		
Cleanse all battery connections with a nylon scouring pad			✓
Cleanse all metallic surfaces with a cleaner wax to maintain the finish of the lift			✓

* When using the disinfection solution avoid direct contact with the skin and eyes. In the event of a contamination incident - immerse the seat belt or stability vest in the disinfection solution for 10 min. and then rinse thoroughly with fresh water.

TROUBLE SHOOTING

Be sure the battery is fully charged before troubleshooting.

Lift does not rotate

Does lift raise or lower?

Yes.

1. Check connection to Control Box. Be sure plug is pushed in all the way.
2. Check hand control connection to Control Box for damaged pins.
3. Check connections on terminal block located on frame for loose wires.
4. Check connection cable for damage.
3. Try operating the lift using the control buttons on the front panel of the controller. If the lift rotates when using the buttons on the control box, the hand control is likely the problem.
5. If the lift does not rotate when using the buttons on the control box, reverse the motor cables as follows: Locate the area on the Control Box where the cables are attached. Swap the actuator cable from connector #2 and the 24v motor cable from connector #1. Activate the up and down buttons on the hand control. If lift rotates, the problem is likely the hand control. If lift does not rotate, the problem is likely the 24v motor.
6. Contact your Authorized Reseller or S.R. Smith for component replacement information.

Does lift raise or lower?

No.

1. Check battery charge level.
2. Check battery connection.
3. Use another fully charged battery. If lift continues to not function, replace the Control Box.

Lift does not Raise or Lower

Does lift rotate?

Yes.

1. Check connection to Control Box. Be sure plug is pushed in all the way.
2. Check hand control connection to Control Box for damaged pins.
3. Check connection cable for damage.
4. Activate the up and down buttons on the front panel of the control box. If lift raises and lowers, the problem is likely the hand control.
5. If lift does not raise and lower when using the buttons on the control box, reverse the motor cables as follows: Locate the area on the Control Box where the cables are attached. Swap the actuator cable from connector #2 and the 24v motor cable from connector #1. Activate the left and right buttons on the hand control. If lift raises and lowers, the problem is likely the hand control. If lift does not raise and lower, the problem is likely the Actuator.
6. Contact your Authorized Reseller or S.R. Smith for component replacement information.

Does lift rotate?

No.

1. Check battery charge level.
2. Check battery connection.
3. Use another fully charged battery. If lift does not function, replace the Control Box.

LONG-TERM STORAGE

When storing the lift for an extended period of time:

- Wash seat with disinfection solution and then rinse with fresh water and dry entire lift
- Spray gear assembly with a heavy duty rust inhibitor and lubricant such as LPS 3 - Heavy-Duty Inhibitor
- Keep the battery on the charger in a dry temperature controlled area
- Cover unit and store in a dry location away from pool chemicals

Questions/Comments - Contact us at 800.824.4387 or 503-266-2231 or info@srsmith.com.
For information regarding Authorized Resellers worldwide visit www.srsmith.com

WARRANTY INFORMATION

S.R. Smith, LLC warrants to the original retail purchaser that products manufactured by S.R. Smith, when properly assembled and installed in accordance with S.R. Smith's assembly and installation instructions, and properly used and maintained, shall be free from defects in material and workmanship for a period of three (3) years from the date of original manufacture except for the following items: WetDek™ (1 year) and PoolSonix™ (2 years). The original retail purchaser must follow the procedure set forth below when submitting a warranty claim. S.R. Smith will repair or replace, at its option, the product, and return it to the owner freight prepaid. Determination of repair or replacement shall be solely at the discretion of S.R. Smith. Aquatic lift systems, components and batteries have a separate warranty, set forth below.

All Aquatic Lifting Systems have a three (3) year warranty on the frame, excluding the powder coated paint finish, which may become scratched with normal use. All electronic and motor components, with the exception of batteries, have a full two (2) year warranty. Within the warranty period, S.R. Smith will repair or replace any item deemed to be found defective. Lift batteries come with a one-year pro-rated warranty. During the first 90 days of ownership, batteries will be covered 100%. If a battery failure occurs between day 91 and day 365, batteries are covered at 50% of the original cost. Normal maintenance and care of the unit, including charging of the battery when not in use is recommended. Do not store the unit, battery or components near or around chemicals.

The warranty is non-transferable and is subject to the following terms and conditions ([View complete S.R. Smith Terms & Conditions](#)):

S.R. Smith shall not be responsible for the cost of removal or replacement of any defective S.R. Smith product, nor for any other expenses or for damages which might be incurred in such removal and replacement.

This warranty specifically excludes fading of materials, microbiological staining of diving boards or pool slides and rust or corrosion of any metallic products or parts. Refer to S.R. Smith care and maintenance instructions for regular maintenance and cleaning of S.R. Smith Products. Maintenance instructions can be found at www.srsmith.com/care.php.

This warranty relates only to defects in materials and workmanship and does not include damage or failure resulting from other causes, including, but not limited to Acts of God, misuse or abuse, accident or negligence, fire, improper assembly or installation, chipping or flaking of powder or vinyl coatings, or ice damage. Damage induced by the improper use of chemicals is not covered by this warranty. In the event that products are altered or repaired by anyone without the prior written approval of S.R. Smith, all warranties are void.

IMPORTANT: WEIGHT LIMIT ON DIVING BOARDS, JUMP BOARDS, STANDS, SLIDES, LADDERS AND LADDER STEPS SHALL BE NOT MORE THAN 250 POUNDS. EXCEPTIONS: FRONTIER IV BOARD AND BASE NOT MORE THAN 400 POUNDS. TURBOTWISTER AND TYPHOON SLIDES NOT MORE THAN 275 POUNDS. CYCLONE SLIDE NOT MORE THAN 175 POUNDS. VORTEX SLIDES NOT MORE THAN 325 POUNDS.

S.R. Smith shall not be liable for any consequential, special or incidental damages, including, but not limited to any damages for loss of use of pools or injury to person or property, and any claims therefore are hereby specifically disclaimed and excluded. Some states do not allow the exclusion or limitation of incidental, special or consequential damages, so the above limitation or exclusion may not apply to you. This warranty gives you specific legal rights and you may also have other rights, which may vary from state to state. The warranty is extended to, and enforceable only by the original retail purchaser.

If any S.R. Smith products fail during the warranty period as a result of a defect in material or workmanship covered by this warranty, the original retail purchaser must notify S.R. Smith via www.srsmith.com/warranty.php. This notice from the original retail purchaser must contain all pertinent product information as outlined in the warranty claim form. S.R. Smith will determine if the product is to be returned to the factory or will ask that (1) the defective area and (2) the part of the product stamped with the serial

number be removed and returned. Product pieces must be cleaned and returned freight prepaid to S.R. Smith's facility at either 1017 SW Berg Parkway, Canby, OR 97013 or 105 Challenger Drive, Portland, TN 37418 as determined by S.R. Smith.

THE WARRANTY SET FORTH HEREIN IS IN LIEU OF ALL OTHER WARRANTIES, EXPRESSED OR IMPLIED, WHICH ARE HEREBY DISCLAIMED AND EXCLUDED, INCLUDING WITHOUT LIMITATION ANY WARRANTY OF MERCHANTABILITY OR FITNESS FOR A PARTICULAR PURPOSE OR USE.

THE SOLE AND EXCLUSIVE REMEDIES FOR BREACH OF ANY AND ALL WARRANTIES WITH RESPECT TO THE PRODUCTS SHALL BE LIMITED TO REPAIR OR REPLACEMENT AT S.R. SMITH'S DESIGNATED FACTORY OR IN PLACE AT S.R. SMITH'S OPTION. IN NO EVENT SHALL S.R. SMITH'S LIABILITY EXCEED THE ENTIRE AMOUNT PAID TO S.R. SMITH BY THE ORIGINAL PURCHASER FOR THE FAILED OR DEFECTIVE PRODUCT.

IN NO EVENT SHALL S.R. SMITH BE LIABLE FOR ANY INCIDENTAL, CONSEQUENTIAL, SPECIAL, INDIRECT, PUNITIVE OR EXEMPLARY DAMAGES OR LOST PROFITS FROM ANY BREACH OF THIS LIMITED WARRANTY OR OTHERWISE.

No representative of S.R. Smith, nor any of its agents, distributors or dealers has any authority to alter in any manner the terms of this warranty and S.R. Smith is not responsible for any undertaking, representation or warranty made by any other person beyond the warranty expressly set forth in this warranty.

Warranty Procedures

The S.R. Smith warranty becomes effective on the date of manufacture.

To initiate a warranty replacement, Please follow the process outlined below.

1. **Take photos of the damaged product.**
 - a) The photo must include the entire unit (i.e. board and stand or slide from a distance).
 - b) Also include one photo or more of the damaged area.
2. **Remove the serial # sticker from the product.**
 - a) S.R. Smith provides a serial # for every board, stand, slide and rail product we produce. The sticker with the serial number for our boards, stands and slides is a silver, 1" long rectangular sticker found on the side or bottom of the item. The serial # sticker for our rail products is clear and 2" long. It will be found on the inside of the topmost curve.
3. **Attach the photos and the serial # sticker to a written request for replacement under the S.R. Smith warranty.** Please include the following information:
 - a) Product name and description. (i.e.: board length/color, curve direction of slide, etc.)
 - b) Date of purchase and/or date of installation.
 - c) Description of damage.
 - d) Shipping address with a contact name and phone number.
4. **Return to us by mail or email at www.srsmith.com/warranty.php the photos, serial # sticker and your written request to:**

S.R. Smith, LLC
PO Box 400
1017 SW Berg Pkwy
Canby, OR 97013
Attn: Warranty Specialist

****Please Note:** Missing information will result in a processing delay and possibly denial of your claim.

Should you have any questions regarding this process, please contact S.R. Smith's Warranty specialist at 800.824.4387 or 503-266-2231 or email warranty@srsmith.com

SPECIFICATIONS

PAL²/202-0000

1. Dimensions/Capacity

Overall Height	66"/167.6cm
Base Dimensions	Height 23"/58 cm, length. 47"/119cm, width 28"/71cm
Overall Length with Footrest	119"/302cm (longest possible length)
Overall Length without Footrest	102"/259cm (longest possible length)
Overall Length in Stored position	72"/183cm (raised position, seat facing in)
Total Weight	1010 lb/458 kg
Power	24V DC
Battery Life (Charged)	30 cycles (approximate)
Lifting Capacity	300 lb/136 kg
Maximum Deck Slope	2 degrees
Seat Width	18.5"/47cm

2. Actuator

Lifting	Screw Type Mechanical Actuator
Max. Thrust	1680 lb/7472N
Voltage	24V DC5"/12.7cm Total Lock Swivel
Max. Amp	9
Max. Speed	0.59 inch/sec./1.49cm/sec.

3. Motor

Rotation	24 VDC 13 RPM
Gearing Ratio	9:1

4. Battery

Power	24 VDC, IPX3 Gel Lead Acid
Temperature Range	41 F (5 C) to 104 F (40 C)

5. Range of Motion

Lifting	Variable to configure to each pool. 44"- 58"/112cm – 147cm total travel from highest to lowest point w/ standard actuator.
Seat Depth	18"-20"/46cm – 51cm below water line. Rotation: 240°

6. Noise

Noise level below 50 dB (A), measured according to DS/EN ISO 3746"

7. Materials and Finish

Frame	Powder Coated Stainless Steel
Handle	Powder Coated Aluminum
Housing	Vacuum Formed ABS Plastic
Casters	

Front	Ball Bearing, Stainless Steel, 5"/12.7cm Fixed, Polyurethane Tread
Rear	Ball Bearing, Stainless Steel, 5"/12.7cm Total Lock Swivel, Polyurethane Tread
Arms	Powder Coated Aluminum
Mast	Powder Coated, Stainless Steel
Seat Assembly	Seat: Roto-Molded Plastic Frame: Powder Coated Stainless Steel

PART LIST

Part Number	Description
100-5000A	LA34 Actuator
1001499	4 Button Control
1001555	4 Button Control w/Activation Key
1001495	Replacement Battery Pack
1001530	Battery Charger
120-1100	24v Motor
800-5065	Small Gear
130-1000	Hub Assembly
120-1000	Motor Mount Assembly
152-1100A	Gray, Mast Assembly
152-1200A	Gray, Actuator Arm
152-1300A	Gray, Support Arm
152-1400A	Seat Arm
160-7000A	Gray, Seat Assembly
160-2300A	Gray, Foot Rest
202-2000	PAL ^z Main Frame Assembly
200-2000	Rigid Caster
200-3000	Swivel Caster
220-3100	Concrete Block, PAL ^z
202-6000	PAL ^z Housing Assembly
200-4100	Stabilizer Assembly
202-7000	Gray, PAL ^z Handle
*920-5000	Deck Cover PAL / SPLASH
*910-1000	Console Cover
*AX2320-R	Gray, Chair Armrest - Right
*AX2320-L	Gray, Chair Armrest - Left

*nonstandard items