

Hi DELTA[®]

Sealed Combustion Boilers & Water Heaters



Models HD101 thru 2342B



The Hot Water Management Experts



Up to **87%** thermal efficiency!

Raypak's Hi Delta

Decades of expertise and technological innovations went into creating the Hi Delta boiler, a product that incorporates features sought after by engineers, installers and end-users alike.

In 1948, Raypak introduced the first straight copper finned tube boiler designed with reliability and serviceability in mind. The tradition continues with Raypak's Hi Delta model. It's patented burner "security blanket," an ingenious enhancement that provides a perfected air-gas pathway for complete combustion, makes the Hi Delta the most adaptable sealed-combustion boiler on the market today.

While many manufacturers claim simple, convenient heat exchanger removal, servicing the Hi Delta couldn't be more straightforward. Just open the unit from the front and slide it out on built-in runners.

Adding to the Hi Delta's ease of use is the On-board Diagnostic Center. In the event of an operating problem, this key enhancement allows an on-site technician to quickly review the unit's entire fault history, in easy to understand "real English". No cryptic codes to deal with. Our diagnostic center even offers possible solutions to the problem at hand.

The Hi Delta product family covers the full spectrum of both indoor and outdoor applications including space heating, process heating, pool heating and domestic hot water heating. When installed indoors, the Hi Delta's versatility is revealed in smaller vent diameters, direct-venting and the convenience of stacking without an increased footprint.

Raypak's focus on customer satisfaction goes beyond product design. Like all Raypak boilers, every Hi Delta is factory-fire tested, assuring reliable start-up upon installation.

For over 60 years, Raypak professionals have earned their reputation as The Hot Water Management Experts. From system design through installation and start-up, you can count on your local Raypak Representative and the backing of the industry's best sales staff, applications engineers and service department.

Key Features

- 19 models from 100,000 to 2,340,000 BTUH
- All models indoor/outdoor certified
- Efficiency:
 - 84% Boilers- standard
 - 85% AFUE HD101-HD301
 - 87% Available on Models 302BE-2342BE
 - 85% Water Heaters- standard
 - 98% Condensing system available (see *Specialty Models*)
- Patented burner "security blanket" enhances staged combustion, minimizes installation and start-up issues, and protects burners from metal fatigue
- 105°F minimum inlet water capability on standard models;
- 120°F on 87% boilers
- Copper finned tube heat exchanger; Cupro-nickel available
- AB 1953 low lead compliant
- Bronze headers standard on water heaters, optional on boilers
- Sidewall venting ready; No extractor needed for most applications
- Ducted combustion air ready; TruSeal™ CSA-certified direct-vent available
- Status display and on-board diagnostic center, real english, no codes.
- Meets all NOx regulations

Options

- G-20 – Low Gas Pressure operation (Models 302B-2342B) CSA-certified for 4" WC supply pressure, natural gas only.
- D-14 – Rear vent option available at time of order
- D-21 – TruSeal direct vent air intake system
- A-6 – Right hand water connection

Visit our website at www.raypak.com to find the Raypak representative in your area.

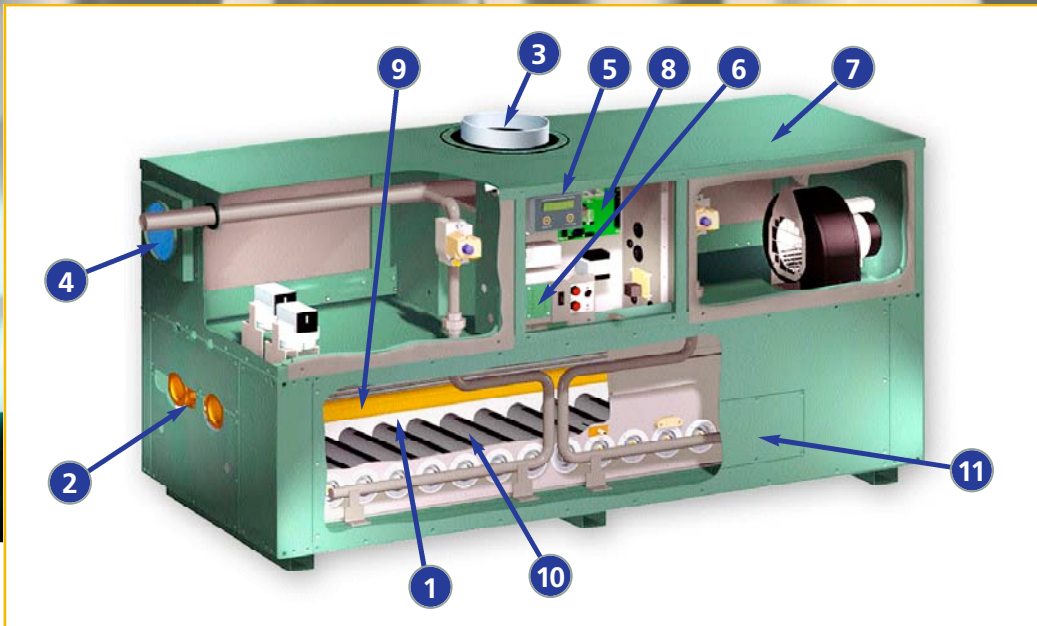

1. Lightweight Refractory Panels

Multi-piece ceramic fiber panels enhance combustion while minimizing heat retention.

2. Fully-enclosed Headers

Temperature sensors and lead wires/capillaries are protected from weather, vandalism, and accidental damage during installation and service.

3. Flue Connection

Top or back outlet flue connections offer greater installation flexibility.

4. Air Filter

An easily-cleaned combustion air filter protects the burners from airborne particles including flying insects.

5. On-Board Diagnostic Center

Factory mounted standard equipment (302-2342). Gives relevant service feedback as well as possible solutions to clear the fault. All in plain English, no cryptic codes to decipher. The control stores up to 16 fault codes in its history file for the service technician to review.

6. Status Display Lights

Up to 12 high-intensity LED lights, visible up-front, indicate the operating status of the boiler.

7. Construction

The cabinet and all internal parts are made from galvanized, aluminized or stainless steel. The exterior is protected by textured powder-coat paint, ideally designed for indoor or outdoor installations.

8. Central Point Wiring

Factory-made wire harnesses connect all electrical components to an easy-to-troubleshoot circuit board with multi-pin connectors.

9. Heat Exchanger Tubes

Time-proven copper finned tubes and optional cupro-nickel tubes stand up to even the harshest water conditions.

10. Burners

Special stainless steel alloy pre-mix burners provide clean, robust combustion and meet all low NOx regulations.

11. HSI Access Panel

A small panel provides access to both the hot surface igniter and the flame sensor to aid inspection and service.

On-Board Diagnostic Center

Raypak's Hi Delta (302B thru 2342B) comes equipped with a microprocessor-controlled diagnostic control center that displays its information on a 2x20 character LCD display in plain English. This control monitors system safeties, ignition faults and system status, while storing up to 16 reported faults. Raypak's diagnostic center also monitors the fault outputs of the Fenwal ignition control. The Fenwal's flash codes are converted into real English fault codes that anyone can understand. The control is also equipped with a SPDT dry contact relay output that is switched anytime a safety fault occurs. This can be used for a heater alarm or a BMS safety interface.

Example Diagnostic Fault Report

Water Flow Sw Fault
Check Boiler Pump, Purge Air, Replace Flow Switch

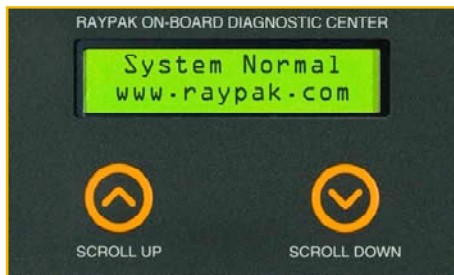

Diagnostic Information

Safety Faults

- Manual High Limit
- Auto High Limit
- Low Water Cut-off
- Vent Pressure
- High Gas Pressure
- Low Gas Pressure
- Controller Alarm
- Flow Switch
- Blower Switch
- Factory Option
- External Interlock
- Cold Water Run

Ignition Control Faults

- Low Air
- Flame- No CFH
- Ignition Lockout
- Low HSI Current
- Low 24VAC
- Internal Control Fault



Sidewall Vent
Category III

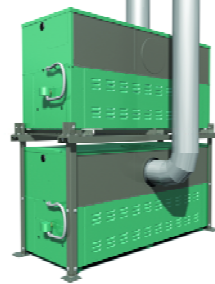

Vertical Venting
Category I (Type B)



See Cat. 1000.16 for complete SureRack Details

Options

SureRack™ Kit

The perfect solution for today's most space challenged equipment rooms. Stacking two Hi Delta 2342 boilers provides over 4.6MMBTU in just over 26 square feet plus clearances. All components (except pumps and PRV's) are contained inside the cabinet, so there won't be any gas valves or fans hanging off the unit. The units remain fully serviceable even while racked.

- For models 302B thru 2342B
- No Vent Offset Required
- Small Footprint
- Fits in Low-Ceiling Room
- Heavy-Duty Construction
- Easy Assembly
- All Hardware Included
- Still Allows for Complete Servicing



98% High-efficiency Hi Delta with optional CHX condensing heating system

Hi Delta with CHX achieves unequalled 98% thermal efficiency at full fire. It combines the reliability of the Hi Delta boiler with an optional CHX heat exchanger which prevents condensation in the heater's primary combustion chamber. Self contained secondary heat exchanger can be inspected and maintained without disturbing the vent or plumbing connections. The result is an ultra high efficiency heater that lasts.
(See Cat. 1000.17)

- For models 402B thru 2002B
- Top or rear CHX mounting options
- Up to 4.0MMBTU if used with the SureRack racking system
- Fully-engineered rack systems simplify jobsite installation and set-up
- Indoor/Outdoor installation
- Fully certified vent systems available
- Straight tube heat exchanger outlasts other designs and facilitates scale-free operation – ideal for DHW applications

Flex Gas™ Dual-fuel boilers and water heaters

With its patented, CSA-certified rapid fuel switchover system, the Hi Delta FlexGas is an ideal solution for interruptible-fuel applications (natural/propane gas).
(See Cat. #1000.20)

- For models 302B thru 2342B
- Changeover takes less than one minute
- No mechanical components to remove or replace
- Changerover can be accomplished while firing: simply turn the key!
- Factory-installed and tested system
- CSA-Certified





Cold Water Start



Cold Water Run

Cold Water Solution Options

Cold Water Start

It is commonly known that prolonged internal condensation will dramatically shorten the life of standard boilers and water heaters. While Raypak boilers and water heaters can operate without harmful condensation at lower inlet water temperatures than the competition, there are still applications that require reliable protection against harmful condensation caused by frequent, extended, cold water start-ups. Raypak's **Cold Water Start** protection system utilizes a proportional three-way valve to bypass water from the boiler outlet to the inlet during start-up, when the system return water temperature is below the minimum acceptable level.

Cold Water Run

For the same reason stated for Cold Water Starts, it is even more important to provide protection against condensation from cold inlet water on systems where the return water temperature to the boiler will always be below the acceptable minimum. Raypak's **Cold Water Run** system utilizes a variable-speed pump to inject just the right amount of water from the main system loop into the boiler to maintain the optimum inlet temperature. This approach allows the full capacity of the boiler to be utilized to meet the system load, while at the same time continuously maintaining the optimum inlet water temperature to prevent condensation. (See Cat. #1000.19)

Simple Serviceability

Raypak's easy-to-understand user interface, including on-board diagnostics and LED operating status lights, tells the technician all he needs to know. All service/repair components are readily accessible from the front for maximum installation flexibility.

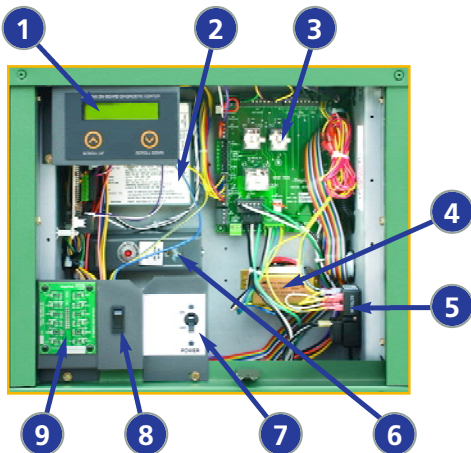

- 1 Diagnostic Control Center
- 2 Fenwal ignition control
- 3 Central point wiring board
- 4 Transformer
- 5 Pump delay relay
- 6 Manual reset high limit
- 7 Main power disconnect
- 8 Standby power switch
- 9 Status lights

Control Options

Raypak's array of leading edge controllers offer features such as: sequence-control of up to 40 boilers; PID technology; optimized approach to outdoor reset; LonWorks or BMS interfacing; freeze protection and other energy-saving functions. Raypak's controllers have been specially designed to maximize the performance of its leading-edge Hi Delta boilers.



TempTracker

Designed to sequence multiple boilers up to four total stages, whether it's one to four on/off boilers, two two-stage boilers, or one boiler with up to four stages. It is available factory-mounted or loose. (See Cat. 5100.22)

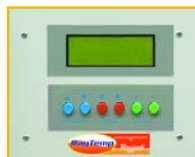

RayTemp

Demand-based set-point control maximizes energy savings in domestic hot water applications (See Cat. 5100.18)



Y-200 Boiler Sequencer

Provides additional functionality for multiple-boiler installations. Compatible with LonWorks® Building Management Systems (BMS) (See Cat. #5100.22)



BOILER

Ref. Dwg. pg. 5	Hi Delta Model	MBTUH Input*	MBTUH Output*			Dimensions (in.)						Operating Weight (lbs.)	Amps‡	
			Type H		Type WH 85%	A Width	B	G NPT	H NPT	K Flue Ø	T Ø			W
			(Cat. I)	87%† (Cat. II)										
1	HD101	100	85	N/A	85	18-9/16	9-1/4	3/4	1-1/2	4	4	N/A	150	4.7
	HD151	150	128	N/A	128	21-7/8	10-7/8	3/4	1-1/2	4	4	N/A	175	4.7
	HD201	199	169	N/A	169	25-1/16	12-1/2	3/4	1-1/2	5	4	N/A	200	4.7
	HD251	250	213	N/A	213	28-5/16	14-1/8	3/4	1-1/2	5	4	N/A	225	4.7
	HD301	299	254	N/A	254	31-9/16	15-3/4	3/4	1-1/2	5	4	N/A	250	4.7
	HD401	399	335	N/A	339	38-1/16	19	3/4	1-1/2	6	4	N/A	300	4.7
2	302B	300	252	261	255	36	18	3/4	2	5	6	18	380	6
	402B	399	335	347	339	43	21-1/2	3/4	2	6	6	18-1/2	445	6
	502B	500	420	435	425	50	25	1-1/4	2	6	6	22	545	6
	652B	650	546	566	553	60-1/2	30-1/4	1-1/4	2	8	6	27-1/4	590	6
	752B	750	630	653	638	67-1/2	33-3/4	1-1/4	2	8	6	30-3/4	675	6
	902B	900	756	783	765	78	39	1-1/4	2	8	6	36	740	7
3	992B	990	832	861	842	57-1/8	28-9/16	2	2-1/2	10	10	16-13/16	900	<12
	1262B	1260	1058	1096	1071	68-1/2	34-1/4	2	2-1/2	12	10	20-9/16	1010	<12
	1532B	1530	1285	1331	1301	79-7/8	39-15/16	2	2-1/2	12	10	24-3/8	1225	<12
	1802B	1800	1512	1566	1530	91-1/8	45-9/16	2	2-1/2	14	10	28-1/8	1350	<12
	2002B ^a	1999	1679	1739	1699	102-1/2	51-1/4	2	2-1/2	14	10	31-15/16	1450	<12
	2072B	2070	1739	1801	1760	102-1/2	51-1/4	2	2-1/2	14	10	31-15/16	1450	<12
	2342B	2340	1966	2036	1989	113-7/8	56-15/16	2	2-1/2	16	10	35-11/16	1520	<12

* Ratings for models HD101-HD401 for natural or propane gas and for elevations up to 2,000 ft. above sea level . For higher elevations, consult the factory.
 Ratings for models 302B-2342B for natural or propane gas and for elevations up to 4,500 ft. above sea level . For higher elevations, consult the factory.

† Add "E" Suffix to model number.

‡ Current draw is for heater only. (Supply breaker must have a delayed trip.)

^a Natural gas only. Not available for propane.

CLEARANCES

Boiler Side	Indoor		Outdoor	
	Minimum	Service	Minimum	Service
Floor*	0"	0"	0"	0"
Rear	1"	24"	12"	24"
Water side	12"	24"	36"	36"
Other side	1"	24"	36"	36"
Top	1"	1"	Unobstructed	Unobstructed
Front	Open	24"	Open	24"
Vent	2"	2"	N/A	N/A

* Do not install on carpeting.

California Bill AB-1953

Raypak is the first manufacturer to fully comply with California bill AB-1953. This is new legislation, mandating the maximum lead content to be less than .25% of the wetted surface area. This legislation went into effect January 1, 2010 and compliance has been verified by CSA.

PUMP - HOT WATER SUPPLY

Hi Delta Model	Water Hardness					
	Soft		Medium		Hard	
	HP	Amps	HP	Amps	HP	Amps
HD101	1/8	1.1	1/8	1.3	1/4	5.7
HD151	1/8	1.1	1/8	1.3	1/4	5.7
HD201	1/8	1.1	1/8	1.3	1/4	5.7
HD251	1/8	1.1	1/8	1.3	1/4	5.7
HD301	1/8	1.1	1/8	1.3	1/4	5.7
HD401	1/8	1.1	1/8	1.3	1/4	5.7
302B	1/8	1.3	1/4	5.7	1/2	7
402B	1/8	1.3	1/4	5.7	1/2	7
502B	1/8	1.3	1/4	5.7	1/2	7
652B	1/8	1.3	1/4	5.7	1/2	7
752B	1/8	1.3	1/2	7	3/4	11
902B	1/4	5.7	1/2	7	3/4	11
992B	1/4	6	1/2	7	3/4	11
1262B	1/4	6	3/4	11	1	14
1532B	1/2	7	1	14	1	14
1802B	3/4	11	1	14	1-1/2	15
2002B	3/4	11	1-1/2	15	1-1/2	15
2072B	3/4	11	1-1/2	15	1-1/2	15
2342B	1	14	1-1/2	15	1-1/2	15

Note: Current draw (Amps) is for pump only.

DRAWING 1 - MODELS HD101-HD401

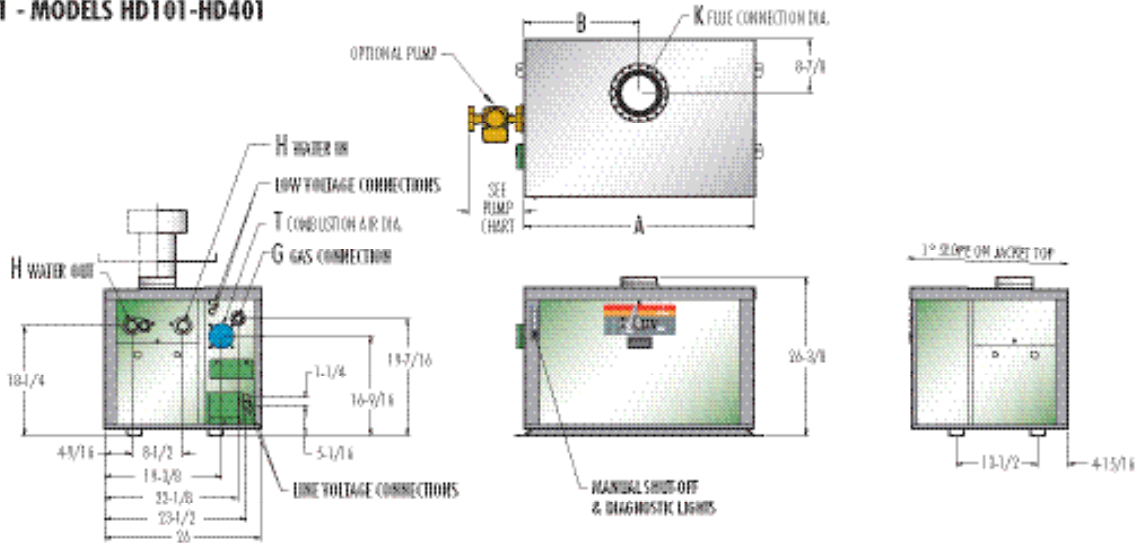

DRAWING 2 - MODELS 302B-902B

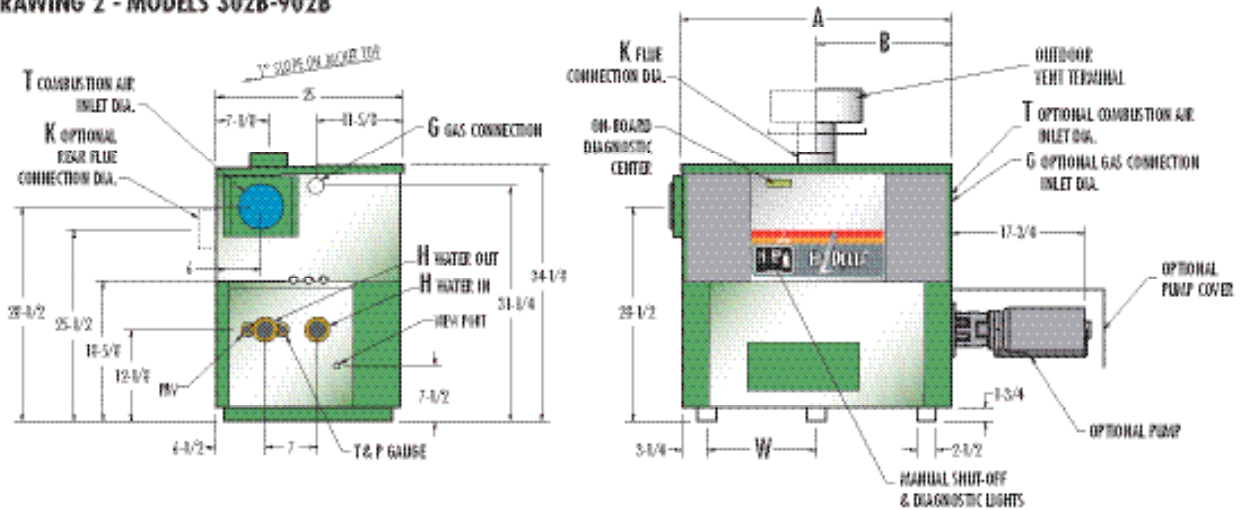

DRAWING 3 - MODELS 992B-2342B

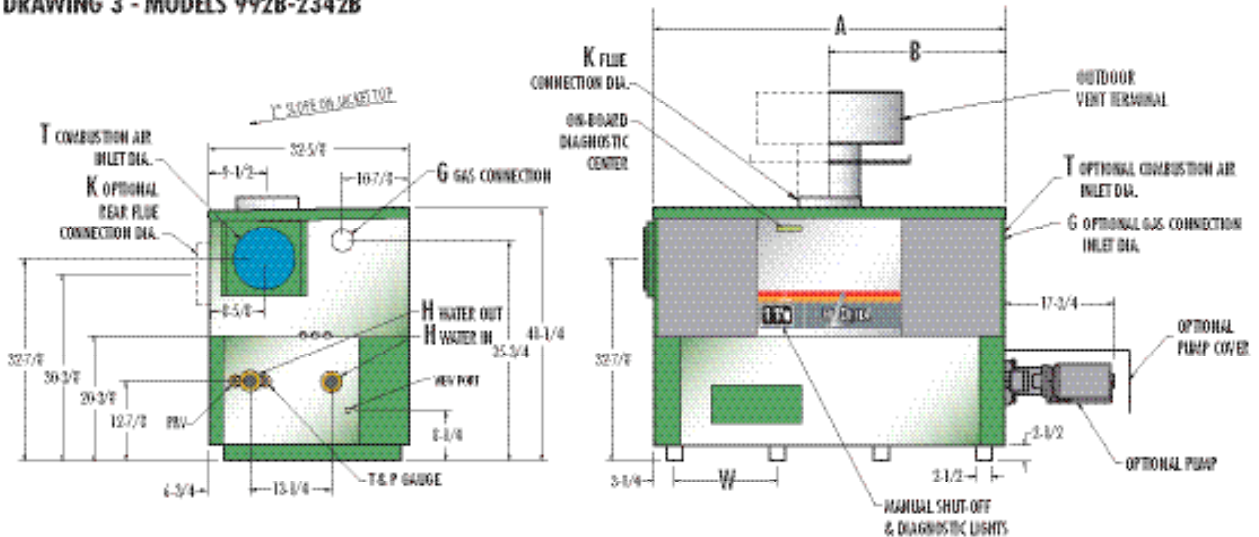

Hi Delta Model	Flow Rates						Pressure Drops									
	Minimum Flow			Maximum Flow			10°F ΔT		20°F ΔT		30°F ΔT		40°F ΔT			
	GPM	ΔP Ft	ΔT °F	GPM	ΔP Ft	ΔT °F	GPM	ΔP Ft	GPM	ΔP Ft	GPM	ΔP Ft	GPM	ΔP Ft		
85% AFUE	HD101	13	<1.0	14	44	8.8	4	17	1.4	Less than Minimum Flow						
HD151	13	<1.0	20	44	8.8	6	26	3.1	13							1.0
HD201	13	3.4	27	44	8.9	8	34	5.4	17	1.3						
HD251	13	<1.0	34	44	9.2	10	43	8.5	21	2.1	14	<1.0				
HD301	13	<1.0	41	44	9.4	12	Exceeds Maximum Flow		25	3.1	17	1.4	13	<1.0		
HD401	22	2.4	30	44	9.8	15			34	5.6	22	2.5	17	1.4		
84% EFFICIENCY (TYPE H)	302B	20	<1.0	25	90	9.8	6	50	3.3	25	<1.0	Less than Minimum Flow				
402B	20	<1.0	34	90	10.0	7	67	5.8	34	1.4	22	<1.0				
502B	21	<1.0	40	90	10.4	9	84	9.1	42	2.3	28	1.1	21	<1.0		
652B	27	1.1	40	90	10.8	12	Exceeds Maximum Flow				55	4.1	36	1.8	27	1.1
752B	32	1.5	40	90	11.3	14					63	5.7	42	2.6	32	1.5
902B	38	2.2	40	90	11.7	17					76	8.3	50	3.8	38	2.2
992B	42	1.3	40	132	13.1	13					83	5.2	55	2.3	42	1.3
1262B	53	2.4	40	132	14.8	16					106	9.6	71	4.3	53	2.4
1532B	64	4.0	40	132	16.5	19					129	15.7	86	7.1	64	4.0
1802B	76	6.0	40	132	18.3	23					101	10.7	76	6.0		
2002B	84	7.9	40	132	19.0	25					112	13.8	84	7.9		
2072B	87	8.5	40	132	19.0	26					116	14.8	87	8.5		
2342B	98	12.1	40	132	21.4	30					131	21.1	98	12.1		

Hi Delta Model	Water Hardness												MTS	
	Soft				Medium				Hard					
	ΔT °F	GPM	ΔP Ft	SHL*	ΔT °F	GPM	ΔP Ft	SHL*	ΔT °F	GPM	ΔP Ft	SHL*		
85% EFFICIENCY (TYPE WH)	HD101	9	20	1.8	3.8	7	26	3.0	6.3	4	45	9.2	18.0	1-1/2"
HD151	13	20	1.8	3.8	10	26	3.1	6.3	6	45	9.2	18.1	1-1/2"	
HD201	17	20	1.9	3.9	13	26	3.2	6.4	8	45	9.4	18.2	1-1/2"	
HD251	21	20	1.9	3.9	16	26	3.2	6.5	9	45	9.6	18.5	1-1/2"	
HD301	25	20	1.9	3.9	20	26	3.2	6.5	11	45	9.8	18.7	1-1/2"	
HD401	31	22	2.4	4.8	26	26	3.3	6.6	15	45	10.3	19.1	1-1/2"	
302B	13	40	2.0	5.1	10	52	3.3	8.3	7	74	6.6	16.3	2"	
402B	17	40	2.0	5.1	13	52	3.4	8.4	9	74	6.8	16.4	2"	
502B	21	40	2.1	5.2	16	52	3.5	8.6	12	73	6.9	16.3	2"	
652B	28	40	2.2	5.3	20	55	4.1	9.7	15	72	7.0	16.2	2"	
752B	30	42	2.6	6.0	17	73	7.5	16.9	14	90	11.3	25.1	2"	
902B	30	51	3.9	8.7	21	73	7.8	17.2	17	90	11.7	25.5	2"	
992B	28	60	2.7	5.2	17	98	7.3	13.3	13	132	13.1	23.6	2-1/2"	
1262B	30	72	4.4	7.9	19	115	11.3	19.4	16	132	14.8	25.3	2-1/2"	
1532B	30	86	7.1	11.9	22	120	13.7	22.5	20	132	16.5	27.0	2-1/2"	
1802B	30	102	10.9	17.4	26	120	15.1	23.9	23	132	18.3	28.7	2-1/2"	
2002B	30	112	13.9	21.6	26	132	19.0	29.5	26	132	19.0	29.5	2-1/2"	
2072B	30	117	15.1	23.4	27	132	19.0	29.5	27	132	19.0	29.5	2-1/2"	
2342B	30	132	21.4	31.8	30	132	21.4	31.8	30	132	21.4	31.8	2-1/2"	

Hi Delta Model	Flow Rates						Pressure Drops									
	Minimum Flow			Maximum Flow			10°F ΔT		20°F ΔT		30°F ΔT		40°F ΔT			
	GPM	ΔP Ft	ΔT °F	GPM	ΔP Ft	ΔT °F	GPM	ΔP Ft	GPM	ΔP Ft	GPM	ΔP Ft	GPM	ΔP Ft		
87% EFFICIENCY (TYPE H)	302BE	20	<1.0	26	90	9.8	6	52	3.3	26	<1.0	Less than Minimum Flow				
402BE	20	<1.0	35	90	10.0	8	69	5.8	35	1.5	23	<1.0				
502BE	22	<1.0	40	90	10.4	10	87	9.1	44	2.5	29	1.1	22	<1.0		
652BE	28	1.1	40	90	10.8	13	Exceeds Maximum Flow				57	4.4	38	2.0	28	1.1
752BE	33	1.6	40	90	11.3	15					65	6.1	44	2.8	33	1.6
902BE	39	2.3	40	90	11.7	17					78	8.9	52	4.1	39	2.3
992BE	43	1.4	40	132	13.1	13					86	5.6	57	2.5	43	1.4
1262BE	55	2.6	40	132	14.8	17					110	10.3	73	4.6	55	2.6
1532BE	67	4.3	40	132	16.6	20					132	16.5	89	7.6	67	4.3
1802BE	78	6.5	40	132	18.3	24					104	11.5	78	6.5		
2002BE	87	8.5	40	132	19.0	26					116	14.8	87	8.5		
2072BE	90	9.1	40	132	19.0	27					120	15.8	90	9.1		
2342BE	102	12.9	40	132	21.4	31					132	22.6	102	12.9		

NOTES: 98% efficiency available with condensing heat exchanger. (See Specialty Models on pg. 4.) Minimum flow rates in closed systems may be reduced to a flow rate consistent with a 40°F ΔT. Maximum flow rates are limited by maximum acceptable velocity through the heat exchanger tubes and may be increased by 10% for closed heating systems. Pressure drop would increase 21%. *SHL = Calculated at 100 feet effective pipe length.



		Recovery Rates (GPH)															
Hi Delta Model	MBTUH Input	Temperature Rise (°F)															
		10	20	30	40	50	60	70	80	90	100	110	120	130	140	150	
85% AFUE	HD101	100	1020	510	340	255	204	170	146	128	113	102	93	85	78	73	68
	HD151	150	1531	765	510	383	306	255	219	191	170	153	139	128	118	109	102
	HD201	199	2031	1015	677	508	406	338	290	254	226	203	185	169	156	145	135
	HD251	250	2551	1276	850	638	510	425	364	319	283	255	232	213	196	182	170
	HD301	299	3051	1526	1017	763	610	509	436	381	339	305	277	254	235	218	203
	HD401	399	4024	2012	1341	1006	805	671	575	503	447	402	366	335	310	287	268
	302B	300	3055	1527	1018	764	611	509	436	382	339	305	278	255	235	218	204
	402B	399	4063	2031	1354	1016	813	677	580	508	451	406	369	339	313	290	271
	502B	500	5091	2545	1697	1273	1018	848	727	636	566	509	463	424	392	364	339
	652B	650	6618	3309	2206	1655	1324	1103	945	827	735	662	602	552	509	473	441
	752B	750	7636	3818	2545	1909	1527	1273	1091	955	848	764	694	636	587	545	509
	902B	900	9164	4582	3055	2291	1833	1527	1309	1145	1018	916	833	764	705	655	611
	992B	990	10080	5040	3360	2520	2016	1680	1440	1260	1120	1008	916	840	775	720	672
	1262B	1260	12829	6415	4276	3207	2566	2138	1833	1604	1425	1283	1166	1069	987	916	855
	1532B	1530	15578	7789	5193	3895	3116	2596	2225	1947	1731	1558	1416	1298	1198	1113	1039
	1802B	1800	18327	9164	6109	4582	3665	3055	2618	2291	2036	1833	1666	1527	1410	1309	1222
	2002B	1999	20353	10177	6784	5088	4071	3392	2908	2544	2261	2035	1850	1696	1566	1454	1357
	2072B	2070	21076	10538	7025	5269	4215	3513	3011	2635	2342	2108	1916	1756	1621	1505	1405
	2342B	2340	23825	11913	7942	5956	4765	3971	3404	2978	2647	2383	2166	1985	1833	1702	1588

		Recovery Rates (GPH)															
Hi Delta Model	MBTUH Input	Temperature Rise (°F)															
		10	20	30	40	50	60	70	80	90	100	110	120	130	140	150	
85% EFFICIENCY (TYPE WH)	HD101	100	1020	510	340	255	204	170	146	128	113	102	93	85	78	73	68
	HD151	150	1531	765	510	383	306	255	219	191	170	153	139	128	118	109	102
	HD201	199	2031	1015	677	508	406	338	290	254	226	203	185	169	156	145	135
	HD251	250	2551	1276	850	638	510	425	364	319	283	255	232	213	196	182	170
	HD301	299	3051	1526	1017	763	610	509	436	381	339	305	277	254	235	218	203
	HD401	399	4071	2036	1357	1018	814	679	582	509	452	407	370	339	313	291	271
	302B	300	3091	1545	1030	773	618	515	442	386	343	309	281	258	238	221	206
	402B	399	4111	2055	1370	1028	822	685	587	514	457	411	374	343	316	294	274
	502B	500	5152	2576	1717	1288	1030	859	736	644	572	515	468	429	396	368	343
	652B	650	6697	3348	2232	1674	1339	1116	957	837	744	670	609	558	515	478	446
	752B	750	7727	3864	2576	1932	1545	1288	1104	966	859	773	702	644	594	552	515
	902B	900	9273	4636	3091	2318	1855	1545	1325	1159	1030	927	843	773	713	662	618
	992B	990	10200	5100	3400	2550	2040	1700	1457	1275	1133	1020	927	850	785	729	680
	1262B	1260	12982	6491	4327	3245	2596	2164	1855	1623	1442	1298	1180	1082	999	927	865
	1532B	1530	15764	7882	5255	3941	3153	2627	2252	1970	1752	1576	1433	1314	1213	1126	1051
	1802B	1800	18545	9273	6182	4636	3709	3091	2649	2318	2061	1855	1686	1545	1427	1325	1236
	2002B	1999	20596	10298	6865	5149	4119	3433	2942	2574	2288	2060	1872	1716	1584	1471	1373
	2072B	2070	21327	10664	7109	5332	4265	3555	3047	2666	2370	2133	1939	1777	1641	1523	1422
	2342B	2340	24109	12055	8036	6027	4822	4018	3444	3014	2679	2411	2192	2009	1855	1722	1607

		Recovery Rates (GPH)															
Hi Delta Model	MBTUH Input	Temperature Rise (°F)															
		10	20	30	40	50	60	70	80	90	100	110	120	130	140	150	
87% EFFICIENCY (TYPE H)	302BE	300	3164	1582	1055	791	633	527	452	395	352	316	288	264	243	226	211
	402BE	399	4208	2104	1403	1052	842	701	601	526	468	421	383	351	324	301	281
	502BE	500	5273	2636	1758	1318	1055	879	753	659	586	527	479	439	406	377	352
	652BE	650	6855	3427	2285	1714	1371	1142	979	857	762	685	623	571	527	490	457
	752BE	750	7909	3955	2636	1977	1582	1318	1130	989	879	791	719	659	608	565	527
	902BE	900	9491	4745	3164	2373	1898	1582	1356	1186	1055	949	863	791	730	678	633
	992BE	990	10440	5220	3480	2610	2088	1740	1491	1305	1160	1044	949	870	803	746	696
	1262BE	1260	13287	6644	4429	3322	2657	2215	1898	1661	1476	1329	1208	1107	1022	949	886
	1532BE	1530	16135	8067	5378	4034	3227	2689	2305	2017	1793	1613	1467	1345	1241	1152	1076
	1802BE	1800	18982	9491	6327	4745	3796	3164	2712	2373	2109	1898	1726	1582	1460	1356	1265
	2002BE	1999	21080	10540	7027	5270	4216	3513	3011	2635	2342	2108	1916	1757	1622	1506	1405
	2072BE	2070	21829	10915	7276	5457	4366	3638	3118	2729	2425	2183	1984	1819	1679	1559	1455
	2342BE	2340	24676	12338	8225	6169	4935	4113	3525	3085	2742	2468	2243	2056	1898	1763	1645

NOTE: 98% efficiency available with condensing heat exchanger. (See Specialty Models on pg. 4.)

HEAT EXCHANGER	ASME, National Board Registered, 160 PSI		H Stamp	●	●	●	N/A	N/A	N/A
			HLW Stamp	N/A	N/A	N/A	●	●	●
Heat Exchanger Tubes	Copper		●	●	●	●	●	●	●
	Cupro Nickel		○	○	○	○	○	○	○
Headers	Bronze		○	○	○	●	●	●	
	Cast Iron		●	●	●	○	○	○	
Pressure Relief Valve	30, 45, 75 & 150 PSI Available		○	○	○	○	○	○	
	60 & 125		●	●	●	●	●	●	
Temperature & Pressure Gauge			●	●	●	●	●	●	
Pump – 120V, Single-Phase			○	○	○	○	○	○	
OPERATING CONTROLS	120V Power Supply		With 120V/24V Transformer	●	●	●	●	●	●
	Pump Time Delay		Single Phase	●	●	●	●	●	●
	Diagnostic Display Central		16-Event Memory	N/A	●	●	N/A	●	●
	Temperature Controller		B-20: On/Off, Mechanical	○	○	○	○	○	○
			B-28: On/Off, Digital	○	○	○	○	○	○
			B-6: 2-Stage, Mechanical	○	○	○	○	○	○
			B-26–B-27: 2-Stage, Digital	○	○	○	○	○	○
			B-21–B-23: 4-Stage, Digital	○	○	○	○	○	○
			B-24: 2-Stage, Raytemp (Digital)	N/A	○	○	N/A	○	○
			B-25: 4-Stage, Raytemp (Digital)	○	○	○	○	○	○
Y-200 Series, Digital	○	○	○	○	○	○			
SAFETIES	Hot Surface Ignition System		3-try	●	●	●	●	●	
			1-try	N/A	○	○	N/A	○	
	High Gas Pressure Switch			○	○	○	○	○	
	Low Gas Pressure Switch			○	○	●	○	●	
	Blocked Vent and Air Pressure Switches			●	●	●	●	●	
	High Limit Switch		Manual Reset, Fixed	●	N/A	N/A	●	N/A	N/A
			Manual Reset, Adjustable	○	●	●	○	●	●
Automatic Reset, Adjustable			○	(1)	○	○	○	○	
Low Water Cut-Off, 24V		With manual reset and test button	○	○	○	○	○	○	
Flow Switch			●	●	●	●	●		
GAS TRAIN	Firing Mode		On/Off (H4, WH1)	○	(2)	○	●	(2)	○
			2-Stage (H3, WH3)	●	(3)	○	○	(3)	○
			3-Stage (H8, WH8)	N/A	N/A	(4)	N/A	N/A	(4)
			4-Stage (H9, WH9)	N/A	N/A	(5)	N/A	N/A	(5)
	4" WC Supply Pressure		Natural Gas Only	●	○	(6)	●	○	(6)
AIR	TruSeal Direct Vent System			●	○	○	●	○	○
	Air Filter, Room Air			●	●	●	●	●	●
	Air Filter, Ducted Outside Air			●	○	○	●	○	○
OTHER	Efficiency		84% (Category I)	●	●	●	N/A	N/A	N/A
			(98% available; See Specialty Models)	N/A	N/A	N/A	●	●	●
			(402B - 2002B only)	N/A	○	○	N/A	N/A	N/A
	Combustible Floor Rated			●	●	●	●	●	●
	Alarm System			○	○	○	○	○	○
	Vent Terminal		Outdoor and Through-the-Wall	○	○	○	○	○	○
	Right-Hand Water Connections			○	○	○	○	○	○
	CSD-1/GE GAP Control System			N/A	(7)	○	N/A	(7)	○
	Low NOx Compliance		Meets all current requirements	●	●	(8)	●	●	(8)
	Cold Water Start		Cold water protection systems	N/A	○	○	N/A	○	○
Cold Water Run		Cold water protection systems	○	○	○	○	○	○	

Notes:
 1 Standard on on/off boilers (H4); Optional on all others
 2 Standard on Models 302B and 402B; Optional on Models 502B-902B
 3 Optional on Models 302B and 402B; Standard on Models 502B-902B
 4 Standard on 992B; Optional on 1262B-2342B
 5 Not available on Model 992B; Standard on Models 1262B-2342B
 6 Option but not available on Model 2002B
 7 Not applicable for Models 302B and 402B; Optional for Models 502B-902B
 8 Standard on Models 992B-2002B; Models 2072B and 2342B require site testing and have different emissions requirements (Consult factory)

● ● = Standard ○ ○ = Optional

